

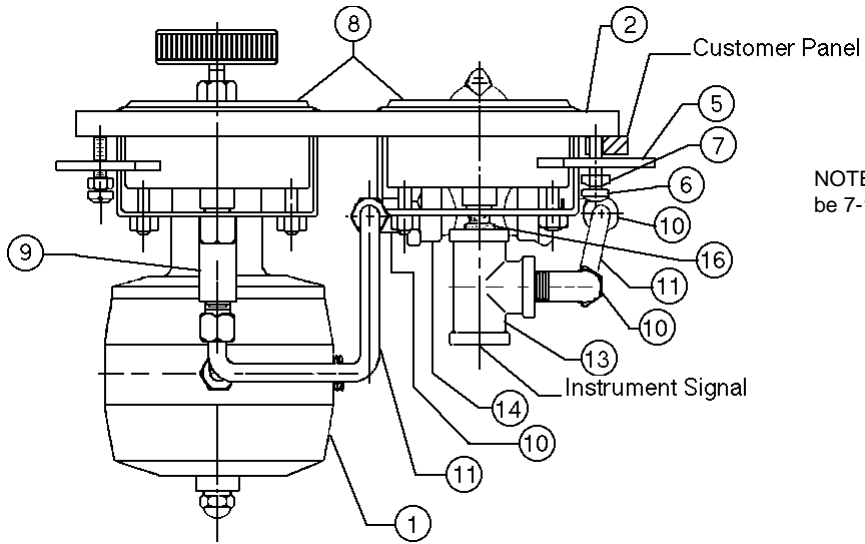

# MODEL 5486 AUTOMATIC-MANUAL LOADING STATION

Dwg. No. A52-00254-00  
3-9-87



NOTE: Panel Cutout to be 7-1/2" x 7-1/2"

ITEM #	DESCRIPTION
1	5100P Air Supply Regulator
2	Panel
3	Application Plate
4	Fillister Head Screw
5	Clamp
6	Fillister Head Screw
7	Hex. Nut
8	Gauge
9	Tube Fitting (Female Run Tee)
10	Tube Fitting (Elbow)
11	Tubing
12	Application Plate
13	Tee
14	3-Way Valve
15	Fillister Head Screw
16	Bushing
18	Selection Plate

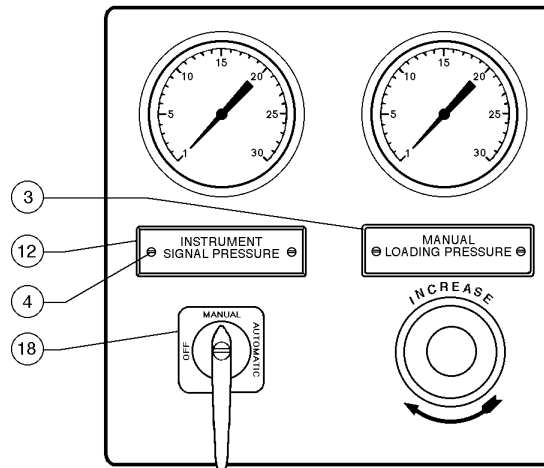
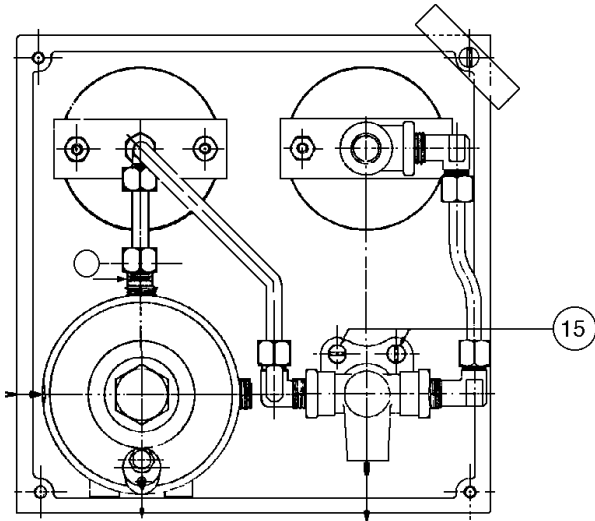

ISO 9001  
Registered

Cashco, Inc.  
P.O. Box 6  
Ellsworth, KS 67439-0006  
PH (785) 472-4461  
Fax. # (785) 472-3539  
Sales@Cashco.com OR Exportsales@Cashco.com  
Printed in U.S.A. Model 5486-TB