

MODEL P1

SINGLE STAGE PRESSURE REDUCING REGULATOR

SECTION I

I. DESCRIPTION AND SCOPE

The Model P1 is a pressure reducing regulator used to control downstream (outlet or P_2) pressure. Sizes are 1/4" and 3/8" (DN8 and DN10). The unit is suitable for gaseous or liquid services. Refer to Technical Bulletin P1-TB for design conditions and selection recommendations.

SECTION II

II. INSTALLATION



CAUTION A

Installation of adequate overpressure protection is recommended to protect the regulator from overpressure and all downstream equipment from damage in the event of regulator failure.

1. An inlet block valve should always be installed.
2. If service application is continuous such that shutdown is not readily accomplished, it is recommended that an inlet block valve, outlet block valve, and a manual bypass valve be installed.
3. Pipe unions should be installed to allow removal from piping.
4. An outlet pressure gauge should be located approximately ten pipe diameters downstream, and within sight.
5. All installations should include a downstream relief device if the inlet pressure could exceed the pressure rating of any downstream equipment or the maximum outlet pressure rating of the unit.
6. Clean the piping of all foreign material including chips, welding scale, oil, grease and dirt before installing the regulator. Strainers are recommended.
7. In placing thread sealant on pipe ends prior to engagement, ensure that excess material is removed and not allowed to enter the regulator upon startup.
8. Flow Direction: Install so the flow direction matches the inlet stamp on the main regulator body (1).
9. For best performance, install in well drained horizontal pipe.
10. Basic Regulator - (Refer to Figure 2, Model P1): Regulator may be rotated around the pipe axis 360°. Recommended position is with aluminum knob (4) vertical upwards.
11. Regulators are not to be buried underground.
12. For insulated piping systems, recommendation is to not insulate regulator.

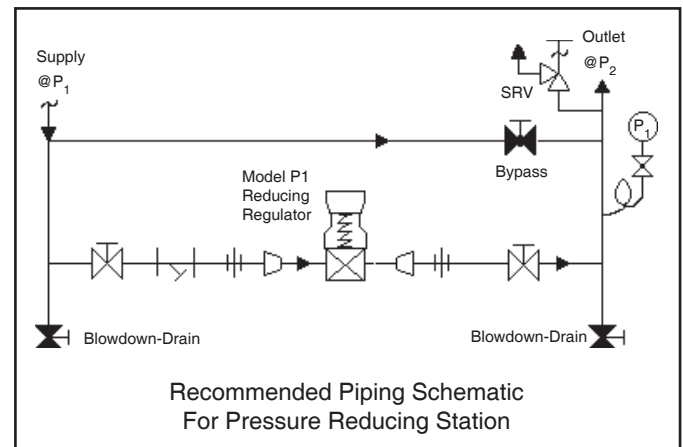

SECTION III

III. PRINCIPLE OF OPERATION

1. Movement occurs as pressure variations register on the diaphragm (7). The registering pressure is the outlet, P_2 , or downstream pressure. The range spring (15) opposes diaphragm (7) movement. As outlet pressure drops, the range spring (15) pushes the diaphragm (7) down, opening the

port; as outlet pressure increases, the diaphragm (7) pushes up and the port opening closes.

2. A complete diaphragm (7) failure will cause the regulator to fail open.

SECTION IV

IV. STARTUP



CAUTION B

The maximum outlet pressure is stamped on the body as the upper range spring pressure level, and is the recommended "upper operative limit" for the sensing diaphragm (see Section IV. Startup, Step 7). Higher pressures could damage the diaphragm. (Field hydrostatic tests frequently destroy diaphragms. DO NOT HYDROSTATIC TEST THRU AN INSTALLED UNIT; ISOLATE FROM TEST.)

1. Start with the block valves closed. A bypass valve may be used to maintain outlet pressure in the downstream system without changing the following steps.
2. Relax the range spring (15) by turning the aluminum knob (4) counter clockwise (CCW) until rotation comes to a complete stop.
3. If it is a "hot" piping system, and equipped with a bypass valve, slowly open the bypass valve to preheat the system piping and to allow slow expansion of the piping. Closely monitor outlet (downstream) pressure via gauge to ensure not over-pressurizing. NOTE: If no bypass valve is installed, extra caution should be used in starting up a cold system; i.e. do everything slowly.
4. Crack open the outlet (downstream) block valve.
5. Slowly open the inlet (upstream) block valve ob-

serving the outlet (downstream) pressure gauge. Determine if the regulator is flowing. If not, slowly rotate the regulator aluminum knob (4) clockwise (CW) until flow begins.

6. Continue to slowly open the inlet (upstream) block valve until fully open.
7. Continue to slowly open the outlet (downstream) block valve, especially when the downstream piping system isn't pressurized. If the outlet (downstream) pressure exceeds the desired pressure, close the block valve and go to Step 2, then return to Step 4.
8. When flow is established steady enough that the outlet (downstream) block valve is fully open, begin to slowly close the bypass valve if installed.
9. Develop system flow to a level near its expected normal rate, and reset the regulator set point by turning the aluminum knob (4) CW to increase outlet pressure, or CCW to reduce outlet pressure.
10. Reduce system flow to a minimum level and observe set point. Outlet pressure will rise from the set point of Step 9. The maximum rise in outlet pressure on decreasing flow should not exceed the stated upper limit of the range spring (15) by greater than 10%; i.e. 2-100 psig (.14-6.9 Barg) range spring (15). (Example: at low flow the outlet pressure should not exceed 110 psig (7.6 Barg), if it does, consult factory).

SECTION V

V. SHUTDOWN

1. On systems with a bypass valve, and where system pressure is to be maintained as the regulator is shut down, slowly open the bypass valve while closing the inlet (upstream) block valve. Fully close the inlet (upstream) block valve. (When on bypass, the system pressure must be constantly observed and manually regulated. Close the outlet (downstream) block valve.



CAUTION C

Do not walk away and leave a bypassed regulator unattended.

2. If the regulator and system are to both be shut down, slowly close the inlet (upstream) block valve. Close the outlet (downstream) valve only if regulator removal is required.

SECTION VI

VI. MAINTENANCE



WARNING 1

SYSTEM UNDER PRESSURE. Prior to performing any maintenance, isolate the regulator from the system and relieve all pressure. Failure to do so could result in personal injury.

A. General:

1. Maintenance procedures hereinafter are based upon removal of the regulator unit from the pipeline where installed.
2. Owner should refer to owner's procedures for removal, handling, cleaning and disposal of nonreusable parts, i.e. gaskets, etc.
3. Refer to Figure 2 for Model P1 basic regulator and Figure 1 for the diaphragm subassembly.



CAUTION D

To prevent damage to body, use soft jaws when placing body in a vise. Position so that vise closes over the flats on lower end of body.



WARNING 2

SPRING UNDER COMPRESSION. Prior to removing spring chamber, relieve range spring compression by turning the aluminum knob counter clockwise (CCW) until rotation comes to a complete stop. Failure to do so may result in flying parts that could cause personal injury.

B. Diaphragm Replacement - Model P1:

1. Securely install the body (1) in a vise with the aluminum knob (4) directed upwards.
2. Relax range spring (15) by turning the aluminum knob (4) counter clockwise (CCW) until rotation comes to a complete stop. NOTE: It is not necessary to remove the aluminum knob (4) before removing the spring chamber (6) from the body (1).
3. Remove spring chamber (6) by grasping the flats and turning CCW. Upon removal, the range spring (15), range spring clip (16), and spring button (5) should remain inside the spring chamber (6).

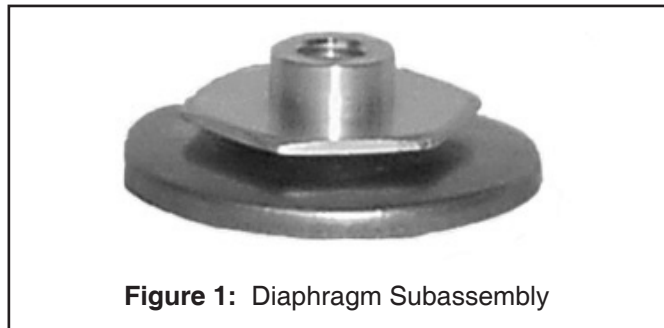

Figure 1: Diaphragm Subassembly

4. Remove diaphragm subassembly (7) consisting of the actuator nut (7.3), diaphragm (7.1), actuator post (7.2), actuator gasket (7.4), actuator o-ring (7.5). Remove diaphragm gasket (10).
5. Remove actuator nut (7.3) and separate all parts of the diaphragm subassembly (7).
6. Clean body (1) diaphragm flange and all reusable parts according to owner's procedures. Do not scratch diaphragm gasket seating surface. NOTE: On regulators originally supplied as "oxygen clean", Option-M, maintenance must include a level of cleanliness equal to Cashco's cleaning standard #S-1134. Contact factory for details.
7. Inspect and replace any necessary parts. NOTE: Use only parts manufactured and supplied by Cashco, Inc. for these products. See Section VIII.
8. Reassemble diaphragm subassembly (7) by placing the actuator gasket (7.4), diaphragm (7.1), and actuator o-ring (7.5) over the threads of the actuator post (7.2). Place a thread sealant compound on the threads of the actuator post (7.2) prior to installing the actuator nut (7.3). Install actuator nut (7.3) and tighten to the following torque value: **ALL SIZES: 15 Ft-lbs (20 Nm).**
9. Place the diaphragm gasket (10) onto the body (1) diaphragm flange. Place diaphragm subassembly onto the body (1).
10. Lubricate the threads of the body (1) with a lightweight grease that is compatible with service use. Rotate the spring chamber (6) CW by hand onto the threaded portion of the body (1) until firmly seated against the diaphragm gasket (10). Tighten to the following torque value: **ALL SIZES: 65–70 Ft lbs (88–95 Nm).**

11. Pressurize with air and spray liquid leak detector around body (1) and spring chamber (6) to test for leakage. Ensure that an outlet pressure is maintained during this leak test of at least mid-range spring level; i.e. 2-100 psig (.14-6.9 Barg) range spring, 51 psig (3.5 Barg) test pressure minimum.

C. Trim Replacement:

1. Remove spring chamber (6) and diaphragm subassembly (7) per Section VI, Steps B.1. – B.4.
2. Remove seat retainer (13) by turning CCW.
3. Remove poppet (8) and poppet spring (9).
4. Clean debris from within the body (1) cavity. Clean all parts to be reused according to owner's procedures. NOTE: On regulators originally supplied as "oxygen clean", Option-M, maintenance must include a level of cleanliness equal to Cashco's cleaning standard #S-1134. Contact factory for details.
5. Inspect all parts for damage and replace if necessary. NOTE: Use only parts manufactured and supplied by Cashco, Inc. for these products. See Section VIII.
6. Place poppet spring (9) into body (1) cavity.

7. Place poppet (8) inside the poppet spring (9). The angled seating surface of the poppet (8) must face up toward the seat (12).
8. Install new seat retainer (13) with seat (12) into body (1) cavity with the seat (12) facing downward toward the angled seating surface of the poppet (8). Tighten seat retainer (13) to the following torque value: **ALL SIZES:** 12 – 15 Ft-lbs (16 – 20 Nm).
9. Reinstall diaphragm subassembly (7) and spring chamber (6) per Section VI, Steps B.9. – B.10.
10. Bench test unit for suitable operation. NOTE: Regulators are not tight shutoff devices. Even if pressure builds up beyond set point, a regulator may or may not develop bubble tight shutoff.
11. Pressurize with air and spray liquid leak detector around body (1) and spring chamber (6) to test for leakage. Ensure that an outlet pressure is maintained during this leak test of at least mid-range spring level; i.e. 2-100 psig (.14-6.9 Barg) range spring, 51 psig (3.5 Barg) test pressure minimum.

SECTION VII

VII. TROUBLE SHOOTING GUIDE

1. Erratic operation; chattering.

Possible Causes	Remedies
A. Oversized regulator; inadequate rangeability.	A1. Check actual flow conditions, re-size regulator for minimum and maximum flow. A2. Increase flow rate. A3. Decrease regulator pressure drop; decrease inlet pressure by placing a throttling orifice in inlet piping union. A4. Install next step higher range spring. A5. Before replacing regulator, contact factory.
B. Worn poppet; inadequate guiding.	B. Replace trim (possible body replacement).
C. Weakened/broken poppet spring.	C. Replace poppet spring. Determine if corrosion is causing the failure.

2. Regulator can't pass sufficient flow.

Possible Causes	Remedies
A. Regulator undersized.	A1. Confirm by opening bypass valve together with regulator. A2. Check actual flow conditions, re-size regulator; if regulator has inadequate capacity, replace with larger unit.
B. Incorrect range spring (adjusting aluminum knob CW does not raise pressure to proper level).	B. Replace range spring with proper higher range.
C. Too much droop.	C1. Review droop expected. C2. Contact factory.

3. Sluggish operation.

Possible Causes	Remedies
A. Fluid too viscous.	A. Heat fluid. Contact factory.

4. Excessive pressure downstream.

Possible Causes	Remedies
A. Regulator not closing tightly.	A. Inspect the seating. Clean and lap metal seat surfaces; replace if lapping does not remedy. If composition seats are depressed, nicked or embedded with debris, replace trim.
B. Downstream block.	B. Check system; isolate (block) flow at regulator inlet - not outlet. Relocate regulator if necessary.
C. No pressure relief protection.	C. Install safety relief valve, or rupture disc.
D. Restricted diaphragm movement.	D. Ensure no moisture in spring chamber at temperatures below freeze point.

SECTION VIII

VIII. ORDERING INFORMATION: NEW REPLACEMENT UNIT vs PARTS "KIT" FOR FIELD REPAIR

To obtain a quotation or place an order, please retrieve the Serial Number and Product Code that was stamped on the metal name plate and attached to the unit. This information can also be found on the Bill of Material (parts list) that was provided when unit was originally shipped.) (Serial Number typically 6 digits). Product Code typical format as follows: (last digit is alpha character that reflects revision level for the product).

□□□□ - □□□□ 7 - □□□□□□□□□□

NEW REPLACEMENT UNIT:

Contact your local Cashco, Inc., Sales Representative with the Serial Number and Product code. With this information they can provide a quotation for a new unit including a complete description, price and availability.

PARTS "KIT" for FIELD REPAIR:

Contact your local Cashco, Inc., Sales Representative with the Serial Number and Product code. Identify the parts and the quantity required to repair the unit from the Bill of Materials sheet that was provided when unit was originally shipped.

NOTE: *Those part numbers that have a quantity indicated under "Spare Parts" in column "A" reflect minimum parts required for inspection and rebuild, - "Soft Goods Kit". Those in column "B" include minimum trim replacement parts needed plus those "Soft Goods" parts from column "A".*

If the "BOM" is not available, refer to the cross-sectional drawings included in this manual for part identification and selection.

Local Sales Representative will provide quotation for appropriate Kit Number, Price and Availability.



CAUTION

Do not attempt to alter the original construction of any unit without assistance and approval from the factory. All purposed changes will require a new name plate with appropriate ratings and new product code to accomodate the recommended part(s) changes.

NOTES

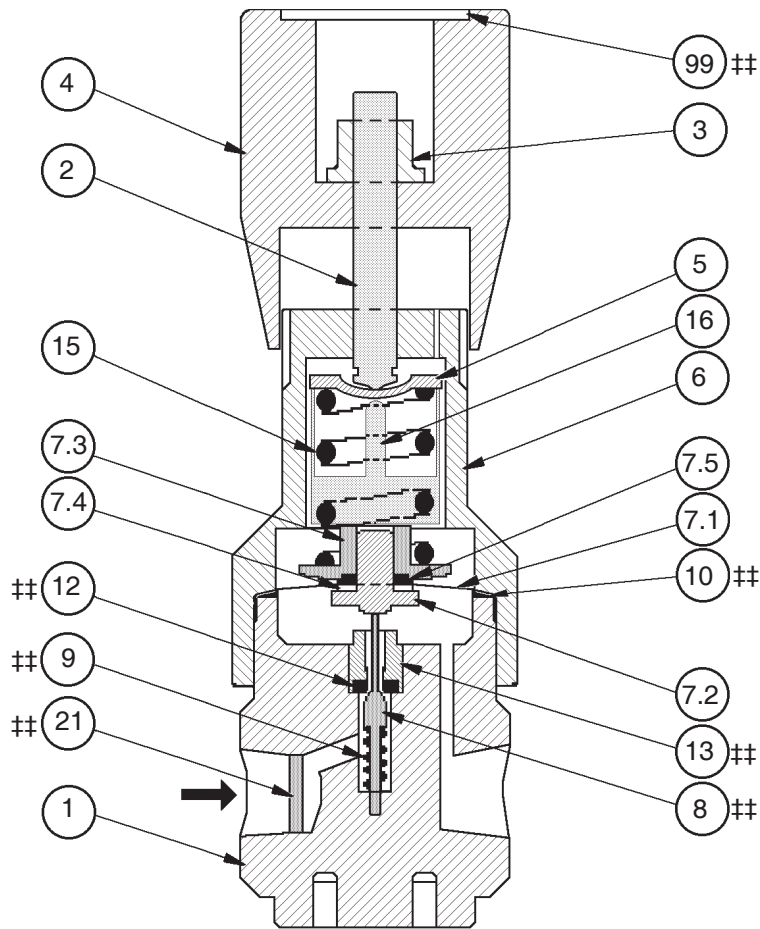

Figure 2: Model P1

Item No.	Description	Repair Parts Kit B
1	Body	
2	Adjusting Screw	
3	Knob Nut	
4	Aluminum Knob	
5	Spring Button	
6	Spring Chamber	
7	Diaphragm Subassembly -----	##
7.1	Diaphragm	
7.2	Actuator Post	
7.3	Actuator Nut	
7.4	Actuator Gasket	
7.5	Actuator O-ring	
8	Poppet -----	##
9	Poppet Spring -----	##
10	Diaphragm Gasket -----	##
12	Seat -----	##
13	Seat Retainer -----	##
15	Range Spring	
16	Range Spring Clip	
21	Inline Filter-----	##
99	Metal Logo-----	##

Cashco, Inc. d/b/a Sensiflo
P.O. Box 6
Ellsworth, KS 67439-0006
PH (785) 472-4461
Fax. # (785) 472-3539
www.cashco.com
email: sales@cashco.com
exportsales@cashco.com
Printed in U.S.A. Model P1-IOM