



MODEL FL-800 S and V

Barstock Thermal Shutoff Valves

INSTRUCTION NO. IOM-FL-800

REFERENCE DATA:

FL-800 Series Assembly Drawing No. A66-60800-00, A66-60800-01, A66-60800-02 & A66-60800-03.

INSTALLATION:

1. Clean the piping of all foreign material including chips, welding scale, oil, grease and dirt before installing the thermal trip valve.
2. In placing thread sealant on pipe ends prior to engagement, ensure that excess material is removed and not allowed to enter the thermal trip valve upon startup.
3. Flow Direction: Install so the flow direction matches the flow arrow on the body of the thermal trip valve.

PRINCIPLE OF OPERATION:

1. When the valve is installed it is open.
2. This valve will stay open until it is actuated by the fusible link.
3. This will cause the valve to close.

MAINTENANCE:

1. All valves are leak tested at the factory at 450 psig and should be externally leak tight after installation. If after prolonged service the valve should leak externally, it is recommended the valve be replaced or sent to the factory for rebuilding.

BARSTOCK THERMAL SHUT-OFF VALVES FL-800 SERIES

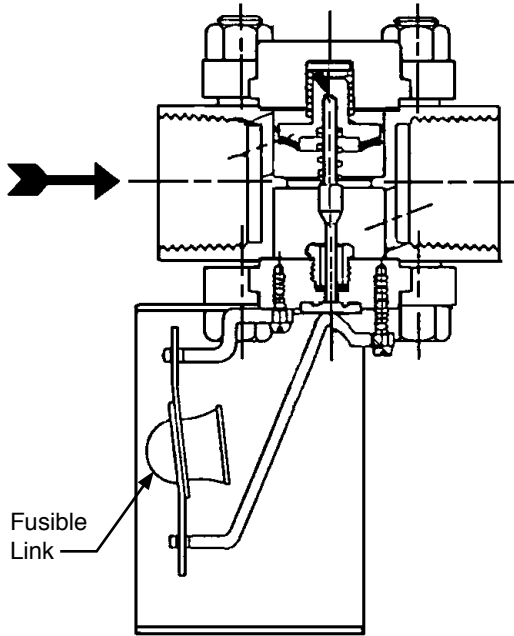

Type S (Standard)
View 2

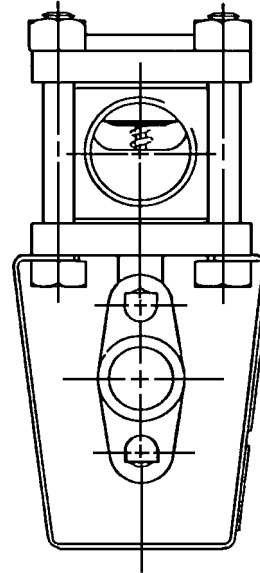

View 1

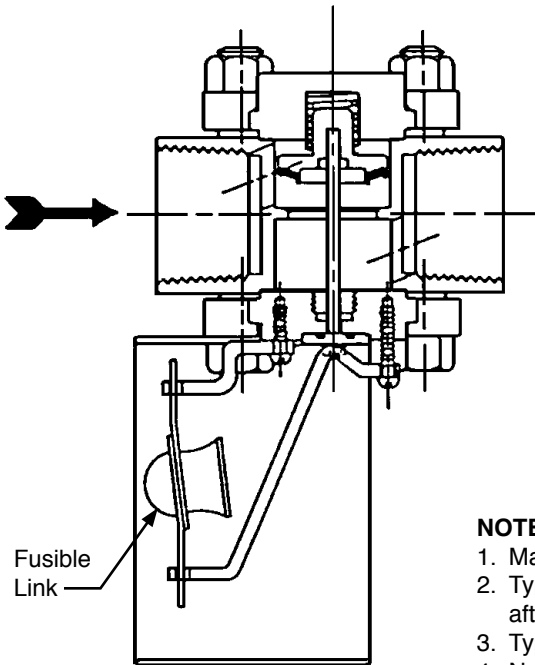

Type V (Vented)
View 3

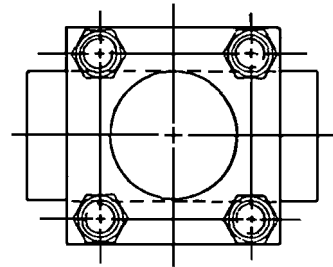

NOTES:

1. Maximum pressure rating 300 psig (2069 kPa) WOG.
2. Type S (Standard) Shut-off valve will not allow venting of downstream line after valve has actuated.
3. Type V (Vent) Shut-off valve will allow venting of downstream line.
4. No changes shall be made to parts, materials or manufacturing process without prior approval by Factory Mutual Research Corporation.
5. All valves to be assembled, inspected and tested in strict accordance with Cashco standard S-1668.