



MODEL 3171

MODEL 3171 BACK PRESSURE RELIEF REGULATOR

The Model 3171 is a stainless steel back pressure relief regulator designed to handle small to mid-capacity flow rates in sanitary biotechnical process piping systems. This unit is capable of controlling inlet pressure to a level between 5 and 200 psig (.34 and 13.8 Barg).

FEATURES

- High Stability:** High mass plug allows dampening of high frequency disturbances from inlet or outlet side of regulator.
- Trim Removal:** Easily removeable trim from regulator while in-line.
- Non-Asbestos Construction:** Standard gasketing of non-asbestos material.
- Materials Construction:** All metallic parts are SST. Unit is cleaned to Cashco Spec. #S-1576.
- Surface Finish:** Interior of body surface electro-polished to #32 micro-inch R_a finish with electro-polished exterior.

APPLICATIONS

Used in pharmaceutical industry in production of many health care products for both human and animal consumption. Widely applied for processed food production — candy, beverages, nutritional supplements and artificial sweeteners. May also be used in cosmetics production and specialty chemicals.

Would be found supporting fermenters, batching tanks, cookers, dryers and other similar equipment.



CAUTION

This is not a safety device and must not be substituted for a code approved pressure safety relief valve or rupture disc.

STANDARD/GENERAL SPECIFICATIONS

Body Size and Material: 1/2" (DN15)
Wrought Barstock; ASTM A479, Type 316L SST.

Body Connection: Standard - Sanitary "Tri-Clamp®".
Designed to seal against weld-type clamp liners per ISO 2852.

Spring Chamber Materials: Standard - Cast SST; ASTM A351, Grade CF3M.

Trim:

PART	S1L	SET
Diaphragm	302 SST	EPDM
Diaphragm Cover	-	TFE
Piston	316L SST	316L SST
Seat ¹	316L SST	TFE
Seat Screw	-	316 SST
Temperature Range °F (°C)	-20 to +400 (-29 to +205)	-20 to +300 (-29 to +149)

¹The fixed portion of the seat is integral to the body. Indicated seat is the moving portion and is attached or integral with the piston.

Gaskets: Standard: TFE Gaskets; TFE O-rings at diaphragm and piston locations.

Operating Temperature: -20 to +400°F (-29° to +205°C)

Inlet Pressure: 240 psig (16.5 Barg) maximum

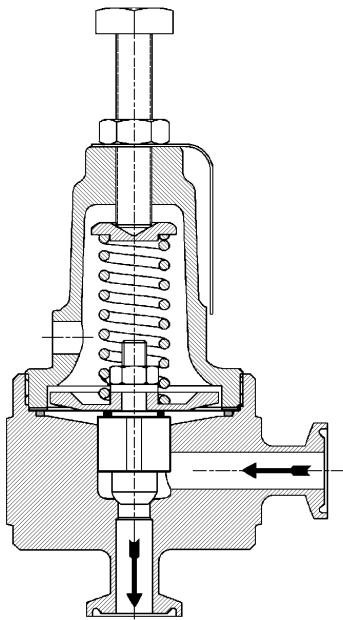

Figure 1: Metal Seat Design

Range Springs: Standard: SST

Range Spring		Maximum Build
psig	(Barg)	
5-30	(.34-2.1)	20%
20-80	(1.4-5.5)	20%
70-140	(4.8-9.6)	20%
130-200	(9.0-13.8)	20%

Cv's/Capacities: See Tables 1, 2, 3, and 4.

Cleaning: All units cleaned per Cashco Spec. #S-1576.

NOTE: Refer to "TECHNICAL SPECIFICATIONS" tables for a more complete description of the above specifications.

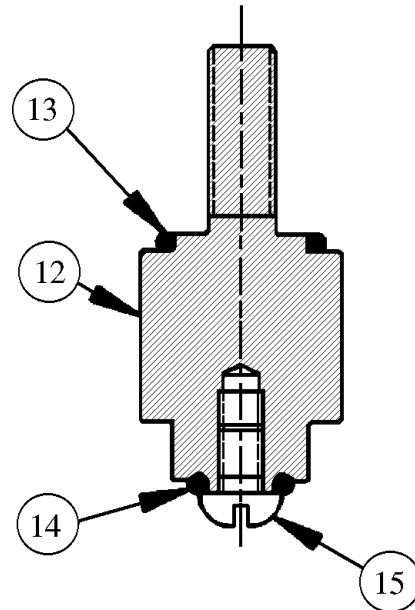

Figure 2: Composition Seat Design
(Refer to IOM for Part Identification)

TECHNICAL SPECIFICATIONS

TABLE 1
CAPACITY - Cv
(FL = 0.95)
1/2" Size

SETPOINT (P1) PRESSURE (psig)	METAL DIAPHRAGM		COMPOSITION DIAPHRAGM	
	% BUILD		% BUILD	
	10%	20%	10%	20%
10	.05	.10	.07	.14
25	.09	.18	.11	.22
50	.09	.18	.11	.22
75	.12	.25	.16	.31
100	.08	.17	.10	.20
125	.09	.18	.11	.22
150	.03	.07	.05	.10
200	.07	.14	.09	.17

TABLE 2
WATER CAPACITY - GPM
S.G. = 1.0 T - 60°F FL = 0.95, 1/2" Size -
Composition Diaphragm Only

OUTLET PRESSURE (psig)	SETPOINT PRESSURE (psig)	1/2" BODY % BUILD	
		10%	20%
ATM	10	0.2	0.5
	25	0.6	1.2
	50	0.8	1.7
	75	1.5	CAV
	100	CAV	CAV
5	10	0.2	0.4
	25	0.5	1.1
	50	0.8	1.6
	75	1.4	CAV
	100	1.0	CAV
	125	CAV	CAV
10	25	0.5	1.0
	50	0.7	1.6
	75	1.4	2.8
	100	1.0	CAV
	125	1.2	CAV
15	25	0.4	0.9
	50	0.7	1.5
	75	1.3	2.7
	100	1.0	2.0
	125	1.2	CAV
	150	0.6	CAV
25	200	CAV	CAV
	50	0.6	1.3
	75	1.2	2.5
	100	0.9	1.9
	125	1.2	2.5
25	150	0.6	CAV
	200	1.3	CAV

NOTE: Where "CAV" is indicated, water has reached full cavitation and flow is choked.

TABLE 3
AIR CAPACITY - SCFH
S.G. = 1.0 T - 60°F F_L - 0.95, 1/2" Size
Composition Diaphragm Only

OUTLET PRESSURE (psig)	SETPOINT PRESSURE (psig)	1/2" BODY % BUILD	
		10%	20%
ATM	50	270	580
	75	550	1150
	100	440	950
	125	590	1280
	150	320	690
	200	750	1530
25	75	540	1140
	100	440	950
	125	590	1280
	150	320	690
50	200	750	1530
	100	420	900
	125	580	1250
	150	320	680
100	200	750	1530
	125	410	890
	150	270	580
150	200	700	1450
	200	570	1160

TABLE 4
STEAM - LBS/HR
S.G. = Actual T = Saturated F_L = 0.95, 1/2" Size
Metal Diaphragm Only

OUTLET PRESSURE (psig)	SETPOINT PRESSURE (psig)	1/2" BODY % BUILD	
		10%	20%
ATM	50	11	23
	75	20	43
	100	17	38
	125	23	48
	150	9	22
	200	28	HI VEL
10	50	11	22
	75	20	42
	100	17	38
	125	23	48
	150	9	22
25	200	28	57
	75	19	41
	100	17	37
	125	23	47
50	150	9	22
	200	28	57
	100	16	35
	125	22	46
100	150	9	21
	200	27	56
	125	17	36
	150	8	19
100	200	26	54

NOTES: Where "HI VEL" is indicated within the above capacity tables, outlet velocity with 1/2" tube has reached 0.35 x Sonic Velocity, an accepted practical velocity limit. Flow is the last indicated value in the column above "HI VEL".

DIMENSIONS AND WEIGHTS

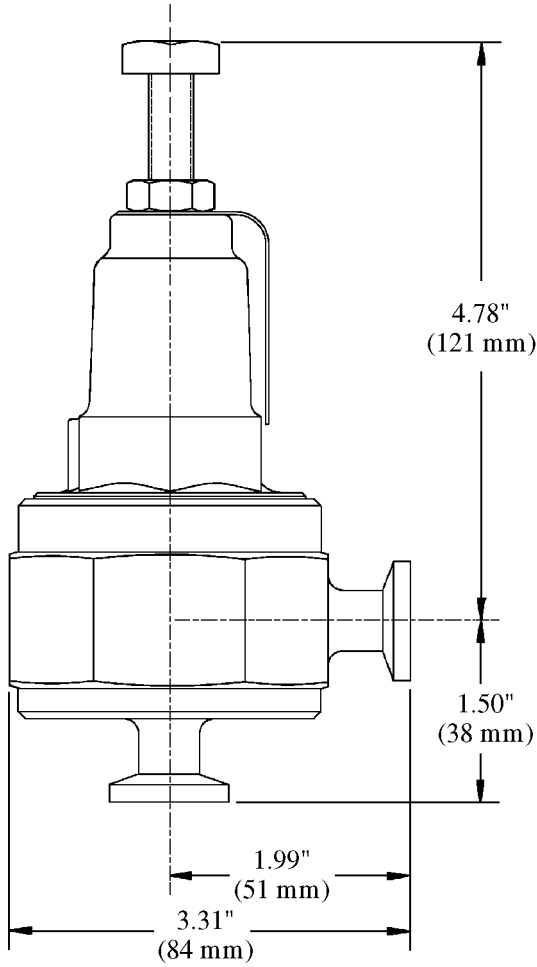

Weight = 3 Lbs.
(1.36 kgs)

MODEL 3171 PRODUCT CODE 09/05/07

FOR THE FOOD AND PHARMACEUTICAL INDUSTRY

L
S
4
-
A
Table
1
7
-
1
Table
2
6
0
0
0
0
0
0
B

TABLE 1 – TRIM DESIGNATION NUMBERS	
Desig.	CODE
S1L*	L1
SET	ST

* Trim utilize on steam service only.

TABLE 2 – RANGE SPRINGS		
SST Range Spring		CODE
psig	(Barg)	
5-30	(.34-2.1)	A
20-80	(1.4-5.5)	B
70-140	(4.8-9.7)	C
130-200	(9.0-13.8)	D

OPTIONS		
Description	Option	CODE
Wetted Parts Cert 'U' (USP)	Std	6
For Special Construction Other Than Above Contact Cashco for Special Product Code		
1. NUMERIC digits assigned first in "ascending" order. 2. ALPHA designations are assigned second in "alphabetical" order. 3. Left justify. 4. Add "0" to all unused squares. 5. If insufficient quantity of squares, consult factory for proper code.		

Cashco, Inc.
 P.O. Box 6
 Ellsworth, KS 67439-0006
 PH (785) 472-4461
 Fax. No. (785) 472-3539
 www.cashco.com
 Email: sales@cashco.com OR
 exportsales@cashco.com
 Printed in U.S.A. 3171-TB