



MODEL 345

## MODEL 345

### HIGH PRESSURE REDUCING REGULATOR

The Model 345 is a piston style, heavy duty, high pressure reducing regulator that can include balanced trim with a TFE or nylon seat for controlling downstream pressure between 50 and 3000 psig (3.4 and 207 Barg), with inlet pressures up to 4000 psig (275 Barg). The metal seated version is an unbalanced trim design. Where trim wear is expected, metal seating surfaces may be stellite. Sizes 1/2", 3/4" and 1" (DN15, 20, and 25). Available options include flanged end connections.

#### FEATURES

- High Pressure:** High inlet and outlet pressures; high pressure drops.
- Balanced Trim:** Minimizes the effect of large changes in inlet pressure such as those encountered with bottled gas.
- Tight Shutoff:** TFE or nylon seat provides tight shutoff.
- Adjustment Ease:** Radial roller bearings to reduce frictional forces and wear. Standard T-bar handle.

#### APPLICATIONS

Primarily used as first stage letdown valve on high pressure applications.

Used for controlling clean gases. Handles bottled gas up to 4000 psig (275 Barg) inlet pressure, with a maximum pressure drop of up to 3000 psid (207 Bard).

Use in liquid service is for non-cavitating fluids, i.e. lubricants, up to 1000 psid (69.0 Bard) pressure drop, metal seated.

 **CAUTION**

**DO NOT APPLY IN STEAM SERVICE.**

## STANDARD/GENERAL SPECIFICATIONS

**Body Sizes:** 1/2", 3/4", 1"  
(DN15, 20, and 25).

**End Connections:** Standard: NPT female.  
Opt-30: Weld-on 300#, 600#, 900# or 1500# RF flanges with SST body.

**Body Materials:** AL BRZ = Aluminum Bronze  
ASTMB148, Alloy C95500.  
SST = Cast Stainless Steel  
ASTM A351, Gr. CF8M.

**Spring Chamber Material:** BRZ = Cast Bronze  
ASTMB584, Alloy C90300.

**Inlet Pressure:** Up to 4000 psig (275 Barg).

**Inlet Temperature:** Function of trim materials.  
Up to 400°F (205°C), S1 trim only.  
(See Table 4.)

**Outlet Pressure:** 50 to 3000 psig (3.4 to 206 Barg) with multiple range springs.

**Pressure vs. Temperature Ratings:** May be reduced when available flanged end connections are selected. See Table 1 and Table 10.

**Maximum Pressure Drop:** See Table 2.

**Trim Designs:** Primarily 316 SST material.  
Metal Seat - Unbalanced.  
Composition Seat - Balanced. See Table 4.

**Capacities:** See Tables 6 through 9.  
Recommended practical limit of 20% droop.  
See Table 5 for maximum wide open  $C_v$  level.

**Range Springs:** Epoxy coated steel.

Applicable Seat Design	Range	
	psig	(Barg)
Balanced - Comp *	50 - 150	(3.4 - 10.3)
Balanced - Comp *	125 - 250	(8.6 - 17.2)
All	200 - 600	(13.8 - 41.4)
All	500 - 1000	(34.5 - 69.0)
All	900 - 3000	(62.1 - 207)

\* See Table 6.

**Gaskets:** Standard: Graphite/NBR. NOT SUITABLE FOR OXYGEN SERVICE.

Alternate Material: See Opt-45.

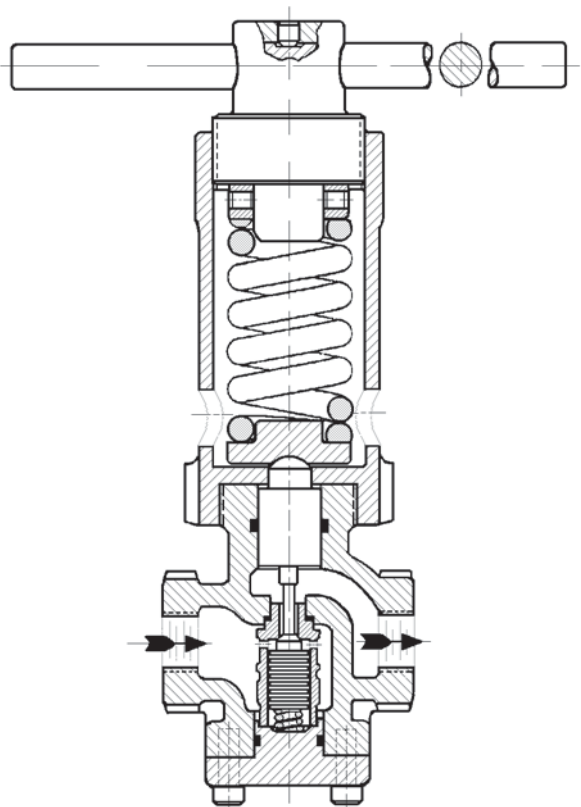

**Figure 1:** Metal Seat, Unbalanced Trim Design

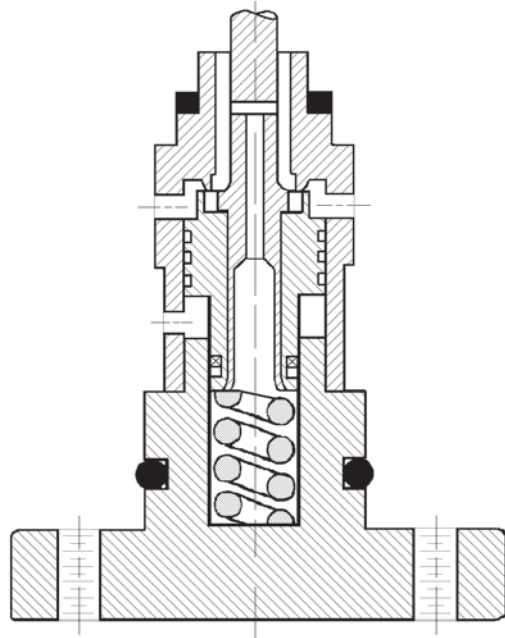

**Figure 2:** Composition Seat, Balanced Trim Design

## OPTION SPECIFICATIONS

This section indicates special variations which are available to the standard Model 345 product. Multiple options may be selected; i.e. 345-15 +30 which is the standard 345 product plus the -15 and the -30 Options together. Care must be exhibited to not develop conflicting combinations; i.e. an aluminum bronze body 345-30.

**Option -15:**     **STELLITED SEATS.** Stellite seating surfaces on unbalanced metal seating piston and cylinder. Can only be applied to S1 trim.

**Option -45:**     **FKM GASKETS.** Primarily for oxygen service. Utilizes FKM gasket over standard gasket.

**Option -30:**     **FLANGED END CONNECTIONS.** Welded-on ASME B16.5 - 300#, 600#, 900#, and 1500# raised face flanges available for 316 SST body. Flanges and nipples of same basic material as body. Nipples are seal welded after screwing into body. Flanges are socket weld design.

**Option -55:**     **SPECIAL CLEANING.** Cleaning per Cashco Spec. #S-1134. Available with SST bodies only. Acceptable cleaning level for oxygen gas service. Use for non-cryogenic service.

**Option -56:**     **SPECIAL CLEANING.** Cleaning per Cashco Spec. #S-1542. Not suitable for oxygen service.

With all flanges, the flange pressure ratings are the pressure limiting factors, not the body inlet rating. (Refer to Table 10 for allowable working pressure vs. temperature tables.)

**Option -95:**     **EPOXY PAINTING.** Two-step epoxy coated for severe ambient conditions to minimize external corrosion. Applied to all exposed parts. Procedures and specifications per Cashco Spec. #S-1547.

See dimension "E" on dimension and weight table, page 11 for face-to-face dimensions of flanged units.

## TECHNICAL SPECIFICATIONS

**TABLE 1  
DESIGN PRESSURE –TEMPERATURE RATINGS  
MATERIAL SPECIFICATIONS**

Standard Construction							
Material Specifications (Body / Spring Chamber)		Inlet Pressure		Outlet <sup>1</sup> Pressure		Temperature <sup>‡</sup>	
Material	ASTM No.	psig	(Barg)	psig	(Barg)	°F	(°C)
AL BRZ/BRZ	B148, C95500/ B584, C90300	4000	(275)	3000	(207)	-70 to +100	(-29 to +38)
		3200	(221)	2700	(186)	+200	(+93)
		2700	(186)	2500	(172)	+300	(+149)
		2500	(172)	2500	(172)	+400	(+205)
SST/BRZ	A351, Gr CF8M B584, C90300	3600	(248)	3000	(207)	-70 to +100	(-29 to +38)
		3100	(214)	2800	(193)	+200	(+93)
		2800	(193)	2500	(172)	+300	(+149)
		2500	(172)	2500	(172)	+400	(+205)

<sup>1</sup> See Table 5 for emergency over-pressures allowed for sizing and selection of safety relief valve.

<sup>‡</sup> The design temperature range of the regulator may be limited by the trim selection. See Table 4.

**TABLE 2  
MAXIMUM ALLOWABLE PRESSURE DROPS**

Fluid	Maximum Recommended Operating Pressure Drop				Seat Design	Trim Designation Number
	Clean Fluid Industrial Quality		Unclean Fluid Pipeline Quality			
	psid	(Bard)	psid	(Bard)		
Liquid	1000 <sup>1</sup>	(69) <sup>1</sup>	600 <sup>1</sup>	(41) <sup>1</sup>	Metal-Stellited Unbalanced	S1
	1000 <sup>1</sup>	(69) <sup>1</sup>	400 <sup>1</sup>	(28) <sup>1</sup>	Metal Unbalanced <sup>1</sup>	S1
	600	(41)	N/R	N/R	Composition Balanced	S3, S3B, S3E
Gas	3000 <sup>1</sup>	(207) <sup>1</sup>	2400 <sup>1</sup>	(166) <sup>1</sup>	Metal-Stellited Unbalanced	S1
	3000 <sup>1</sup>	(207) <sup>1</sup>	600 <sup>1</sup>	(41) <sup>1</sup>	Metal Unbalanced	S1
	3000 @ -20° to +70°F (207 @ -29° to +21°C)		N/R		Composition TFE Balanced	S3, S3B, S3E
	2500 @ +100°F (173 @ +38°C)					
	2000 @ +150°F (138 @ +66°C)					
	3000 @ +70° to +200°F (207 @ +93°C)		N/R		Composition Nylon Balanced	S3Y

<sup>1</sup> Minimum outlet (P<sub>2</sub>) pressure levels apply to unbalanced, metal seat constructions, which may override pressure drop capability.  
N/R: Not recommended.

**TABLE 3  
APPLICATIONS**

Fluid	Recommended Construction	Trim Designation Number
Air or Industrial Chemicals	Clean Fluid; Balanced Composition Seat	S3, S3Y
Chemicals	Clean Fluid; Balanced Composition Seat	S3, S3Y
	Unclean Fluid; Unbalanced Metal Seat	S1
Hydrocarbon Gas or Liquids	Clean Fluid; Balanced Composition Seat	S3, S3Y
	Unclean Fluid; Unbalanced Metal Seat	S1
Water and Condensate 35° to 180°F (2° to 82°C)	Balanced Composition Seat	S3, S3Y
All Fluids except Oxygen †	Balanced Composition Seat	S3B, S3E

† Process Fluid must be compatible with O-ring material.

**TABLE 4  
STAINLESS STEEL TRIM MATERIAL COMBINATIONS**

Part	Stainless Steel Trim Designation Number				
	Unbalanced-Metal	Balanced-Composition			
	S1	S3	S3B	S3E	S3Y (H2, He)
Cylinder	316 SST	316 SST	316 SST	316 SST	316 SST
Piston	316 SST	316 SST	316 SST	316 SST	316 SST
Seat Disc	None	TFE	TFE	TFE	Nylon
Piston Spring	302 SST	302 SST	302 SST	302 SST	302 SST
Cylinder Gasket	Grafoil®	Grafoil®	Grafoil®	Grafoil®	Grafoil®
Pressure Piston	316 SST	316 SST	316 SST	316 SST	316 SST
Body Cap	<sup>1</sup> See below *	<sup>1</sup> See below *	<sup>1</sup> See below *	<sup>1</sup> See below *	<sup>1</sup> See below *
Quad Ring	N/A	Fluorocarbon Elast.	Fluorocarbon Elast.	Fluorocarbon Elast.	Fluorocarbon Elast.
O-rings	Fluorocarbon Elast.	Fluorocarbon Elast.	Buna-N	EPDM	Fluorocarbon Elast.
Backup Ring(s)	TFE	TFE	TFE	TFE	TFE
Temperature Range	-20 to +400° F (-29 to +205° C)	-20 to +150° F (-29 to +66° C)	-40 to +150° F (-40 to +66° C)	-70 to +150° F (-57 to +66° C)	+70 to +200° F (+21 to +93° C)

<sup>1</sup> Brass body cap for aluminum bronze body - 316SST body cap for SST bodies.

N/A: Not applicable

\* For regulators shipped into Canada w/Brass body cap - Material is ASTM B151 C71500.

® Grafoil is a registered trademark of the Union Carbide Corporation.

**NOTE:** Cashco, Inc. does not recommend metal seated trim on any service where the flow will be dead ended downstream of the pressure reducing regulator.



**TABLE 7  
AIR CAPACITIES IN SCFH - (All Sizes)  
S.G. = 1.0 TEMP. = 60°F F<sub>L</sub> = .945**

Outlet Flowing Pressure		Inlet Pressure		1/2" (DN15) Body		3/4" (DN20) Body		1" (DN25) Body	
psig	(Barg)	psig	(Barg)	10% Droop	20% Droop	10% Droop	20% Droop	10% Droop	20% Droop
50	(3.4)	500	(34.5)	7600	15400	7600	15400	7600	15400
		625	(43.1)	9500	19300	9500	19300	9500	19300
		750	(51.7)	11400	SONIC	11400	23100	11400	23100
		1000	(69.0)	15300	SONIC	15300	30900	15300	30900
		1250	(86.2)	19100	SONIC	19100	SONIC	19100	38600
		1500	(103)	SONIC	SONIC	23000	SONIC	23000	46500
		1750	(121)	SONIC	SONIC	26900	SONIC	26900	54400
		2000	(137)	SONIC	SONIC	30800	SONIC	30800	62300
		2250	(155)	SONIC	SONIC	34700	SONIC	34700	SONIC
		2500	(172)	SONIC	SONIC	SONIC	SONIC	38700	SONIC
		2750	(189)	SONIC	SONIC	SONIC	SONIC	42700	SONIC
		3000	(207)	SONIC	SONIC	SONIC	SONIC	46400	SONIC
		3500	(241)	SONIC	SONIC	SONIC	SONIC	54000	SONIC
4000	(276)	SONIC	SONIC	SONIC	SONIC	61400	SONIC		
75	(5.2)	500	(34.5)	10300	19500	10300	19500	10300	19500
		625	(43.1)	12800	24300	12800	24300	12800	24300
		750	(51.7)	15400	SONIC	15400	29200	15400	29200
		1000	(69.0)	20600	SONIC	20600	39000	20600	39000
		1250	(86.2)	25800	SONIC	25800	48800	25800	48800
		1500	(103)	SONIC	SONIC	31000	SONIC	31000	58800
		1750	(121)	SONIC	SONIC	36200	SONIC	36200	68700
		2000	(137)	SONIC	SONIC	41500	SONIC	41500	78700
		2250	(155)	SONIC	SONIC	46800	SONIC	46800	88800
		2500	(172)	SONIC	SONIC	SONIC	SONIC	52200	SONIC
		2750	(189)	SONIC	SONIC	SONIC	SONIC	57500	SONIC
		3000	(207)	SONIC	SONIC	SONIC	SONIC	62600	SONIC
		3500	(241)	SONIC	SONIC	SONIC	SONIC	72800	SONIC
4000	(276)	SONIC	SONIC	SONIC	SONIC	82800	SONIC		
100	(6.9)	500	(34.5)	12400	22600	12400	22600	12400	22600
		625	(43.1)	15500	28300	15500	28300	15500	28300
		750	(51.7)	18600	34000	18600	34000	18600	34000
		1000	(69.0)	24800	SONIC	24800	45400	24800	45400
		1250	(86.2)	31100	SONIC	31100	56800	31100	56800
		1500	(103)	SONIC	SONIC	37400	SONIC	37400	68400
		1750	(121)	SONIC	SONIC	43700	SONIC	43700	80000
		2000	(138)	SONIC	SONIC	50100	SONIC	50100	91600
		2250	(155)	SONIC	SONIC	56500	SONIC	56500	103300
		2500	(172)	SONIC	SONIC	63000	SONIC	63000	SONIC
		2750	(190)	SONIC	SONIC	SONIC	SONIC	69400	SONIC
		3000	(207)	SONIC	SONIC	SONIC	SONIC	75500	SONIC
		3500	(241)	SONIC	SONIC	SONIC	SONIC	87900	SONIC
4000	(276)	SONIC	SONIC	SONIC	SONIC	100000	SONIC		
125	(8.6)	500	(34.5)	14700	25600	14700	25600	14700	25600
		625	(43.1)	18400	32100	18400	32100	18400	32100
		750	(51.7)	22100	38500	22100	38500	22100	38500
		1000	(69.0)	29400	SONIC	29400	51400	29400	51400
		1250	(86.2)	36800	SONIC	36800	64400	36800	64400
		1500	(103)	44300	SONIC	44300	77400	44300	77400
		1750	(121)	SONIC	SONIC	51900	SONIC	51900	90600
		2000	(138)	SONIC	SONIC	59400	SONIC	59400	103800
		2250	(155)	SONIC	SONIC	67000	SONIC	67000	117100
		2500	(172)	SONIC	SONIC	74600	SONIC	74600	130400
		2750	(190)	SONIC	SONIC	SONIC	SONIC	82300	SONIC
		3000	(207)	SONIC	SONIC	SONIC	SONIC	89600	SONIC
		3500	(241)	SONIC	SONIC	SONIC	SONIC	104200	SONIC
4000	(276)	SONIC	SONIC	SONIC	SONIC	118500	SONIC		
150	(10.3)	500	(34.5)	19700	31700	19700	31700	19700	31700
		625	(43.1)	24800	39800	24800	39800	24800	39800
		750	(51.7)	29800	47900	29800	47900	29800	47900
		1000	(69.0)	39700	SONIC	39700	63900	39700	63900
		1250	(86.2)	49700	SONIC	49700	79900	49700	79900
		1500	(103)	SONIC	SONIC	59800	SONIC	59800	96100
		1750	(121)	SONIC	SONIC	70000	SONIC	70000	112400
		2000	(138)	SONIC	SONIC	80200	SONIC	80200	128800
		2250	(155)	SONIC	SONIC	90400	SONIC	90400	145300
		2500	(172)	SONIC	SONIC	SONIC	SONIC	100700	161900
		2750	(190)	SONIC	SONIC	SONIC	SONIC	111100	SONIC
		3000	(207)	SONIC	SONIC	SONIC	SONIC	120900	SONIC
		3500	(241)	SONIC	SONIC	SONIC	SONIC	140700	SONIC
4000	(276)	SONIC	SONIC	SONIC	SONIC	159900	SONIC		
200	(13.8)	500	(34.5)	22100	31100	22100	31100	22100	31100
		625	(43.1)	28100	39500	28100	39500	28100	39500
		750	(51.7)	34000	47800	34000	47800	34000	47800
		1000	(69.0)	45400	63900	45400	63900	45400	63900
		1250	(86.2)	56800	SONIC	56800	79900	56800	79900
		1500	(103)	68400	SONIC	68400	96100	68400	96100
		1750	(121)	SONIC	SONIC	80000	112400	80000	112400
		2000	(138)	SONIC	SONIC	91600	SONIC	91600	128800
		2250	(155)	SONIC	SONIC	103300	SONIC	103300	145300
		2500	(172)	SONIC	SONIC	115100	SONIC	115100	161900
		2750	(190)	SONIC	SONIC	SONIC	SONIC	127000	178500
		3000	(207)	SONIC	SONIC	SONIC	SONIC	138100	194300
		3500	(241)	SONIC	SONIC	SONIC	SONIC	160800	SONIC
4000	(276)	SONIC	SONIC	SONIC	SONIC	182800	SONIC		
250	(17.2)	500	(34.5)	8300	16000	8300	16000	8300	16000
		625	(43.1)	10800	20700	10800	20700	10800	20700
		750	(51.7)	13200	25300	13200	25300	13200	25300
		1000	(69.0)	17700	34000	17700	34000	17700	34000
		1250	(86.2)	22200	42600	22200	42600	22200	42600
		1500	(103)	26700	51300	26700	51300	26700	51300
		1750	(121)	31200	60000	31200	60000	31200	60000
		2000	(138)	35800	68700	35800	68700	35800	68700
		2250	(155)	40400	77500	40400	77500	40400	77500
		2500	(172)	45000	SONIC	45000	86300	45000	86300
		2750	(190)	49600	SONIC	49600	95200	49600	95200
		3000	(207)	54000	SONIC	54000	103600	54000	103600
		3500	(241)	62800	SONIC	62800	120600	62800	120600
4000	(276)	71400	SONIC	71400	137100	71400	137100		

**NOTE:** Where "SONIC" is indicated within the above capacity tables, outlet velocity with Schedule 160 pipe has reached sonic velocity of 1118 fps. Additional flow cannot be obtained, and pipeline velocity is in excess of customary pipe velocity design limits. Flow will be approximately the last indicated value in the column above "SONIC".

**TABLE 7 (cont.)  
AIR CAPACITIES IN SCFH - (All Sizes)  
S.G. = 1.0 TEMP. = 60°F F<sub>L</sub> =.945**

Outlet Flowing Pressure		Inlet Pressure		1/2" (DN15) Body		3/4" (DN20) Body		1" (DN25) Body			
psig	(Barg)	psig	(Barg)	10% Droop	20% Droop	10% Droop	20% Droop	10% Droop	20% Droop		
300	(20.7)	500	(34.5)	8900	16900	8900	16900	8900	16900		
		625	(43.1)	12000	22700	12000	22700	12000	22700		
		750	(51.7)	14800	28000	14800	28000	14800	28000		
		1000	(69.0)	20100	38100	20100	38100	20100	38100		
		1250	(86.2)	25300	47900	25300	47900	25300	47900		
		1500	(103)	30400	57700	30400	57700	30400	57700		
		1750	(121)	35600	67500	35600	67500	35600	67500		
		2000	(138)	40800	77300	40800	77300	40800	77300		
		2250	(155)	46000	87200	46000	87200	46000	87200		
		2500	(172)	51300	97100	51300	97100	51300	97100		
		2750	(190)	56500	SONIC	56500	107100	56500	107100		
		3000	(207)	61500	SONIC	61500	116600	61500	116600		
3500	(241)	71600	SONIC	71600	135600	71600	135600				
4000	(276)	81400	SONIC	81400	154200	81400	154200				
400	(27.6)	500	(34.5)	9000	15500	9000	15500	9000	15500		
		625	(43.1)	14100	24100	14100	24100	14100	24100		
		750	(51.7)	18200	31300	18200	31300	18200	31300		
		1000	(69.0)	25600	44000	25600	44000	25600	44000		
		1250	(86.2)	32600	56000	32600	56000	32600	56000		
		1500	(103)	39400	67700	39400	67700	39400	67700		
		1750	(121)	46200	79300	46200	79300	46200	79300		
		2000	(138)	53000	90900	53000	90900	53000	90900		
		2250	(155)	59700	102500	59700	102500	59700	102500		
		2500	(172)	66600	114200	66600	114200	66600	114200		
		2750	(190)	73400	126000	73400	126000	73400	126000		
		3000	(207)	79900	SONIC	79900	137100	79900	137100		
3500	(241)	92900	SONIC	92900	159500	92900	159500				
4000	(276)	105700	SONIC	105700	181300	105700	181300				
500	(34.5)	625	(43.1)	13500	22300	13500	22300	13500	22300		
		750	(51.7)	19600	32500	19600	32500	19600	32500		
		1000	(69.0)	29400	48800	29400	48800	29400	48800		
		1250	(86.2)	38100	63300	38100	63300	38100	63300		
		1500	(103.4)	46500	77200	46500	77200	46500	77200		
		1750	(120.7)	54800	90900	54800	90900	54800	90900		
		2000	(137.9)	62900	104400	62900	104400	62900	104400		
		2250	(155.2)	71000	117900	71000	117900	71000	117900		
		2500	(172.4)	79100	131300	79100	131300	79100	131300		
		2750	(189.6)	87300	144800	87300	144800	87300	144800		
		3000	(206.9)	95000	157600	95000	157600	95000	157600		
		3500	(241.4)	110500	SONIC	110500	183400	110500	183400		
4000	(275.9)	125700	SONIC	125700	208500	125700	208500				
750	(51.7)	1000	(69.0)	19800	34400	19800	34400	19800	34400		
		1250	(86.2)	29100	50000	29100	50000	29100	50000		
		1500	(103)	37200	63900	37200	63900	37200	63900		
		1750	(121)	44800	76800	44800	76800	44800	76800		
		2000	(138)	52000	89300	52000	89300	52000	89300		
		2250	(155)	59200	101500	59200	101500	59200	101500		
		2500	(172)	66200	113600	66200	113600	66200	113600		
		2750	(190)	73200	125700	73200	125700	73200	125700		
		3000	(207)	79800	136900	79800	136900	79800	136900		
		3500	(241)	92900	159500	92900	159500	92900	159500		
		4000	(276)	105700	181300	105700	181300	105700	181300		
		1000	(69.0)	1250	(86.2)	18400	27600	18400	27600	18400	27600
1500	(103)			26800	40200	26800	40200	26800	40200		
1750	(121)			33900	50900	33900	50900	33900	50900		
2000	(138)			40400	60700	40400	60700	40400	60700		
2250	(155)			46600	70000	46600	70000	46600	70000		
2500	(172)			52700	79000	52700	79000	52700	79000		
2750	(190)			58600	87900	58600	87900	58600	87900		
3000	(207)			64100	96200	64100	96200	64100	96200		
3500	(241)			75100	112600	75100	112600	75100	112600		
4000	(276)			85600	128400	85600	128400	85600	128400		
1500	(103.4)			1750	(121)	21700	41600	21700	41600	21700	41600
				2000	(138)	31300	60000	31300	60000	31300	60000
		2250	(155)	39200	75000	39200	75000	39200	75000		
		2500	(172)	46300	88600	46300	88600	46300	88600		
		2750	(190)	52900	101200	52900	101200	52900	101200		
		3000	(207)	58900	112800	58900	112800	58900	112800		
		3500	(241)	70500	135000	70500	135000	70500	135000		
		4000	(276)	81400	155700	81400	155700	81400	155700		
		2000	(137.9)	2250	(155)	32500	55400	32500	55400	32500	55400
				2500	(172)	46600	79600	46600	79600	46600	79600
				2750	(190)	58000	99000	58000	99000	58000	99000
				3000	(207)	67800	115700	67800	115700	67800	115700
3500	(241)			85200	145500	85200	145500	85200	145500		
4000	(276)			100800	172100	100800	172100	100800	172100		
2500	(172.4)			2750	(190)	42700	70900	42700	70900	42700	70900
				3000	(207)	60800	100900	60800	100900	60800	100900
				3500	(241)	87700	145500	87700	145500	87700	145500
				4000	(276)	109300	181400	109300	181400	109300	181400
3000	(206.9)			3500	(241)	79000	124200	79000	124200	79000	124200
				4000	(276)	113200	177800	113200	177800	113200	177800

**NOTE:** Where "SONIC" is indicated within the above capacity tables, outlet velocity with Schedule 160 pipe has reached sonic velocity of 1118 fps. Additional flow cannot be obtained, and pipeline velocity is in excess of customary pipe velocity design limits. Flow will be approximately the last indicated value in the column above "SONIC".

 Shaded areas indicate the flow has reached or exceeded a velocity of Mach 0.35, an accepted limit for expanded air on the down stream side. Use of higher velocities normally generate high noise levels

**Metric Conversion Factor: SCFH / 35.31 = Sm<sup>3</sup>/Hr; SCFH / 37.32 = Nm<sup>3</sup>/Hr**

**TABLE 8**  
**WATER CAPACITIES IN GPM - (All Sizes)**  
**S.G. = 1.0 TEMP. = 60°F F<sub>L</sub> =.945**

Outlet Flowing Pressure		Inlet Pressure		1/2" (DN15) Body		3/4" (DN20) Body		1" (DN25) Body	
psig	(Barg)	psig	(Barg)	10% Droop	20% Droop	10% Droop	20% Droop	10% Droop	20% Droop
50	(3.4)	500	(34.5)	9.1	18.5	9.1	18.5	9.1	18.5
		625	(43.1)	CAV	CAV	CAV	CAV	CAV	CAV
75	(5.2)	500	(34.5)	12.0	22.7	12.0	22.7	12.0	22.7
		625	(43.1)	13.6	25.8	13.6	25.8	13.6	25.8
		750	(51.7)	HI DP	HI DP	HI DP	HI DP	HI DP	HI DP
		875	(60.3)	CAV	CAV	CAV	CAV	CAV	CAV
100	(6.9)	500	(34.5)	14.0	25.6	14.0	25.6	14.0	25.6
		625	(43.1)	16.0	29.3	16.0	29.3	16.0	29.3
		750	(51.7)	HI DP	HI DP	HI DP	HI DP	HI DP	HI DP
125	(8.6)	500	(34.5)	16.1	28.1	16.1	28.1	16.1	28.1
		625	(43.1)	18.6	32.4	18.6	32.4	18.6	32.4
		750	(51.7)	HI DP	HI DP	HI DP	HI DP	HI DP	HI DP
150	(10.3)	500	(34.5)	21.0	33.7	21.0	33.7	21.0	33.7
		625	(43.1)	24.4	39.2	24.4	39.2	24.4	39.2
		750	(51.7)	27.4	44.1	27.4	44.1	27.4	44.1
		875	(60.3)	HI DP	HI DP	HI DP	HI DP	HI DP	HI DP
200	(13.8)	500	(34.5)	22.2	31.2	22.2	31.2	22.2	31.2
		625	(43.1)	26.4	37.1	26.4	37.1	26.4	37.1
		750	(51.7)	30.0	42.2	30.0	42.2	30.0	42.2
		875	(60.3)	HI DP	HI DP	HI DP	HI DP	HI DP	HI DP
250	(17.2)	500	(34.5)	7.9	15.2	7.9	15.2	7.9	15.2
		625	(43.1)	9.7	18.6	9.7	18.6	9.7	18.6
		750	(51.7)	11.2	21.5	11.2	21.5	11.2	21.5
		875	(60.3)	HI DP	HI DP	HI DP	HI DP	HI DP	HI DP
300	(20.7)	500	(34.5)	8.1	15.3	8.1	15.3	8.1	15.3
		625	(43.1)	10.3	19.5	10.3	19.5	10.3	19.5
		750	(51.7)	12.1	22.9	12.1	22.9	12.1	22.9
		875	(60.3)	13.7	25.9	13.7	25.9	13.7	25.9
		1000	(69.0)	HI DP	HI DP	HI DP	HI DP	HI DP	HI DP

**NOTE:** Where "CAV" is indicated within the above capacity tables, the water has reached full cavitation, and flow is choked. Shaded areas indicate the flow has reached or exceeded the velocities to the right based on Schedule 80 pipe.

Metric Conversion Factor: GPM X 3.785 = LPM

Size		Max. Vel.
in	(mm)	
1/2"	(DN15)	15 fps
3/4"	(DN20)	17.5 fps
1"	(DN25)	20 fps

**TABLE 9**  
**OIL CAPACITIES IN GPM - (All Sizes)**  
**S.G. = 0.85 TEMP. = 60°F F<sub>L</sub> =.945**

Outlet Flowing Pressure		Inlet Pressure		1/2" (DN15) Body		3/4" (DN20) Body		1" (DN25) Body	
psig	(Barg)	psig	(Barg)	10% Droop	20% Droop	10% Droop	20% Droop	10% Droop	20% Droop
50	(3.4)	500	(34.5)	9.7	19.7	9.7	19.7	9.7	19.7
		625	(43.1)	CAV	CAV	CAV	CAV	CAV	CAV
75	(5.2)	500	(34.5)	12.7	24.2	12.7	24.2	12.7	24.2
		625	(43.1)	14.5	27.5	14.5	27.5	14.5	27.5
		750	(51.7)	HI DP	HI DP	HI DP	HI DP	HI DP	HI DP
100	(6.9)	500	(34.5)	14.9	27.3	14.9	27.3	14.9	27.3
		625	(43.1)	17.1	31.3	17.1	31.3	17.1	31.3
		750	(51.7)	HI DP	HI DP	HI DP	HI DP	HI DP	HI DP
125	(8.6)	500	(34.5)	17.1	29.9	17.1	29.9	17.1	29.9
		625	(43.1)	19.8	34.6	19.8	34.6	19.8	34.6
		750	(51.7)	HI DP	HI DP	HI DP	HI DP	HI DP	HI DP
150	(10.3)	500	(34.5)	22.3	35.9	22.3	35.9	22.3	35.9
		625	(43.1)	26.0	41.8	26.0	41.8	26.0	41.8
		750	(51.7)	29.2	47.0	29.2	47.0	29.2	47.0
		875	(60.3)	HI DP	HI DP	HI DP	HI DP	HI DP	HI DP
200	(13.8)	500	(34.5)	23.6	33.2	23.6	33.2	23.6	33.2
		625	(43.1)	28.1	39.6	28.1	39.6	28.1	39.6
		750	(51.7)	32.0	45.0	32.0	45.0	32.0	45.0
		875	(60.3)	HI DP	HI DP	HI DP	HI DP	HI DP	HI DP
250	(17.2)	500	(34.5)	8.4	16.2	8.4	16.2	8.4	16.2
		625	(43.1)	10.3	19.8	10.3	19.8	10.3	19.8
		750	(51.7)	11.9	22.9	11.9	22.9	11.9	22.9
		875	(60.3)	HI DP	HI DP	HI DP	HI DP	HI DP	HI DP
300	(20.7)	500	(34.5)	8.6	16.3	8.6	16.3	8.6	16.3
		625	(43.1)	11.0	20.8	11.0	20.8	11.0	20.8
		750	(51.7)	12.9	24.4	12.9	24.4	12.9	24.4
		875	(60.3)	14.6	27.6	14.6	27.6	14.6	27.6
		1000	(69.0)	HI DP	HI DP	HI DP	HI DP	HI DP	HI DP

**NOTE:** Where "CAV" is indicated within the above capacity tables, the oil has reached full cavitation, and flow is choked. Shaded areas indicate the flow has reached or exceeded the velocities to the right based on Schedule 80 pipe.

Metric Conversion Factor: GPM X 3.785 = LPM

Size		Max. Vel.
in	(mm)	
1/2"	(DN15)	15 fps
3/4"	(DN20)	17.5 fps
1"	(DN25)	20 fps

**TABLE 10**  
**STAINLESS STEEL FLANGED PRESSURE vs. TEMPERATURE RATINGS – ASME B31.3**

Temperature °F	English Units				Metric Units				Temperature °C
	Working Pressure Classes								
	300 psig	600 psig	900 psig	1500 psig	300 Barg	600 Barg	900 Barg	1500 Barg	
-20 to +100	720	1440	2160	3600	49.6	99.3	148.9	248.2	-29 to +38
200	620	1240	1860	3095	42.7	85.5	128.2	213.4	94
300	560	1120	1680	2795	38.6	77.2	115.8	192.7	149
400	515	1025	1540	2570	35.5	70.7	106.2	177.2	205

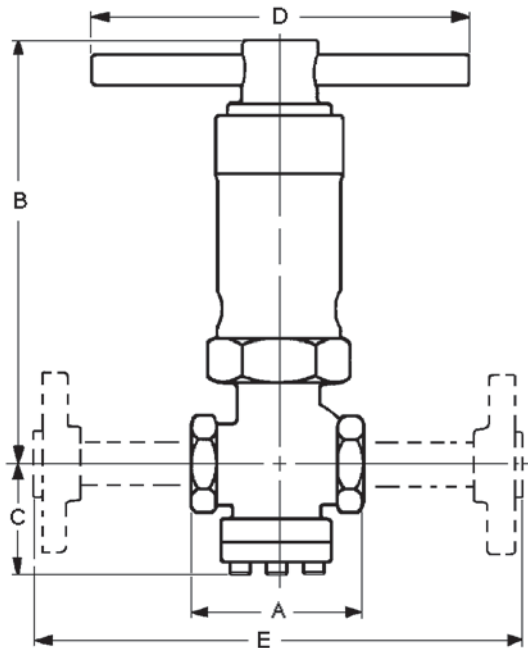

Size (Inches)	DIMENSIONS – ENGLISH UNITS (In)					Shipping Weight ** (lb)
	A	B	C	D	E *	
1/2"	4.50	11.00	3.25	10.00	13.00	27
3/4"						
1"						
Size (DN)	DIMENSIONS – METRIC UNITS (mm)					Shipping Weight ** (kg)
	A	B	C	D	E *	
(15)	114	279	85	254	330	12.2
(20)						
(25)						

\* With Option -30, face-to-face dimensions are the same for all flange pressure ratings.  
 \*\* Weights do not include flanges.

---

## NOTES

---

## NOTES

# MODEL 345 PRODUCT CODE 05/20/10

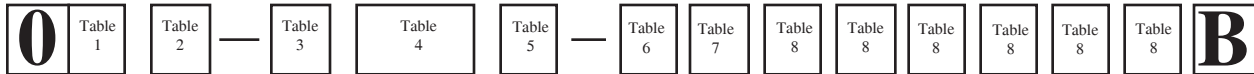

TABLE 1 - GASKETS * & SERVICE		
Gaskets - Service	Options	CODE
Standard : Graphite / NBR - Non-Oxygen	--	<b>B</b>
FKM - Primarily for Oxygen	-45	<b>D</b>
* Refer to Tech Bulletin for temperature limits		

TABLE 2 - SIZES		
Size		CODE
in	(DN)	
1/2"	(15)	<b>4</b>
3/4"	(20)	<b>5</b>
1"	(25)	<b>6</b>

TABLE 3 - BODY / SPRING CHAMBER MATERIALS	
Body / Sp. Ch.	CODE
Al Brz/Brz (Not for use with oxygen service.)	<b>K</b>
SST/Brz	<b>L</b>

TABLE 4 - TRIM DESIGNATION NUMBERS			
Stainless Steel Trim			
Unbalanced		Balanced	
Desig.	CODE	Desig.	CODE
S1	<b>S1</b>	S3	<b>S3</b>
		S3B	<b>3B</b>
		S3E	<b>3E</b>
		S3Y	<b>3Y</b>

TABLE 5 - Product Classification Under European "Pressure Equipment Directive"		
PRODUCT	HAZARD CATEGORY	CODE
Standard	N/A	<b>7</b>
Al Brz - Body Regulators shipped into Canada	NA	<b>C</b>
EUROPEAN * Consult Factory for Special Code	Sound Engineering Practice (SEP)	<b>S</b>
* For products to be placed in service in Europe Ref to Directive 97/23/EC. Forward Completed "EU" Application Recorder prior to quotation.. (Without Recorder- Processing of Purchase Order will be delayed). Contact Cashco for Assistance.		

TABLE 6 - END CONNECTIONS	
Description	CODE
NPT - Screwed	<b>1</b>
-30 Opt.- 300 LB RF Flgs. *	<b>7</b>
-30 Opt.- 600 LB RF Flgs. *	<b>8</b>
-30 Opt.- 900 LB RF Flgs. *	<b>9</b>
-30 Opt.- 1500 LB RF Flgs. *	<b>A</b>
*Nipples & flanges of same material as body. SST bodies only.	

TABLE 7 - RANGE SPRINGS		
Steel Range Spring		CODE
psig	(Barg)	
50 - 150*	(3.4-10.3)	<b>1</b>
125 - 250*	(8.6-17.2)	<b>2</b>
200 - 600	(13.8-41.4)	<b>3</b>
500 -1000	(34.5-69.0)	<b>4</b>
900 -3000	(62-207)	<b>5</b>
* DO NOT use with S1 Trim		

TABLE 8 - OPTIONS		
Description	Option	CODE
No Option	--	<b>0</b>
Stellited Seat Surfaces (SST S1 Trim Only)	-15	<b>A</b>
* Special Cleaning: Per Cashco Spec #S-1134 Suitable for oxygen service	-55	<b>M</b>
Special Cleaning: Per Cashco Spec #S-1542	-56	<b>N</b>
Epoxy Painted	-95	<b>W</b>
* For use with SST bodies only. Must use Code D in Table 1.		
For Special Construction Other Than Above Contact Cashco for Special Product Code		
1. NUMERIC digits assigned first in "ascending" order. 2. ALPHA designations are assigned second in "alphabetical" order. 3. Left justify. 4. Add "0" to all unused squares. 5. If insufficient quantity of squares, consult factory for proper code.		