



MODEL STD 5131 and 5141

BRANDT I/P TRANSDUCER



The Brandt Series STD 5000 is a current-to-pneumatic (I/P) transducer for use in intrinsically safe installations. Using a "Patented Solid State" design, the STD 5000 converts an electronic signal into a proportional pneumatic signal. With its internal feedback network, the STD 5000 responds quickly to step input changes.

FEATURES

- Vibration resistant.
- Low air consumption.
- Mount in any position.
- Intrinsically safe capability.
- Balanced supply & exhaust dynamics.

SPECIFICATIONS

Input Signal: 4-20 mA.

Output Pressure: STD 5131- 3-15 psig (.21-1.03 barg).
STD 5141- 1-17 psig (.07-1.17 barg).

Accuracy: ± 0.15% of span.

Repeatability: ± 0.05% of span.

Deadband: ± 0.02% of span.

Vibration Effect: < 0.25% from 1-200 Hz/1g.

Loop Load: 3.8 Vdc +5 ohms (195 ohm load at 20 mA).

Supply Pressure: STD 5131; 20 psig (1.4 Barg).
STD 5141; 35 psig (2.4 Barg).

Electrical Classification: **USA-Factory Mutual - FM**
Enclosure: NEMA 4X, Hazardous Outdoors Locations, weatherproof.
Explosion Protection: Intrinsically safe, when installed with FM

Electrical

approved and properly rated safety barriers (not provided).

Classification (continued):

Approvals: 4-20 mA input ONLY. Class I, II and III, Div. 1, Applicable Groups A, B, C, D, E, F and G. Class I, Div. 2, Groups A, B, C and D, non-incendive. Class II, Div. 2, Groups F and G. Class III, Div. 2.

Canada-Canadian Stds. Assoc.-CSA

Enclosure: Enc 4.

Explosion Protection: Intrinsically safe, when installed with CSA approved and properly rated safety barriers (not provided).

Approvals: Class I, Groups A, B, C and D, Temp Code T3. Class II, Groups E, F and G.

Output Capacity: 4.0 SCFM (7 SM³/Hr supply and exhaust characteristics are balanced to within ± 10%.

Air Consumption: 0.04 SCFM (0.07 SM³/Hr) Steady State Average, 0.06 SCFM (0.10 SM³/Hr) Maximum.

Operating Temperature: -20°to+150°F (-29°to+66°C).

Temperature Effect: < 1% per 100°F (55°C) change.

Failure Mode: Transducer always fails to the direct mode, i.e. if input current drops below 3.7 mA dc, the output will drop to 1-2 psig (.07-.14

Failure Mode output will drop to 1-2 psig (.07-.14

(continued): Barg) for 3-15 psig output, to 0.5-1 psig (.003-.07 Barg) for 1-17 psig output regardless of direct or reverse mode selection.

Connections: Pneumatic-1/4" NPT, Supply and Output.
Electrical- 1/2" conduit connection.

Materials: Enclosure cap and body- aluminum.

Painting: Chromate primer, powder coat epoxy final finish.

TYPICAL PIPING SCHEMATICS FOR CONTROL VALVE WITH I/P TRANSDUCER

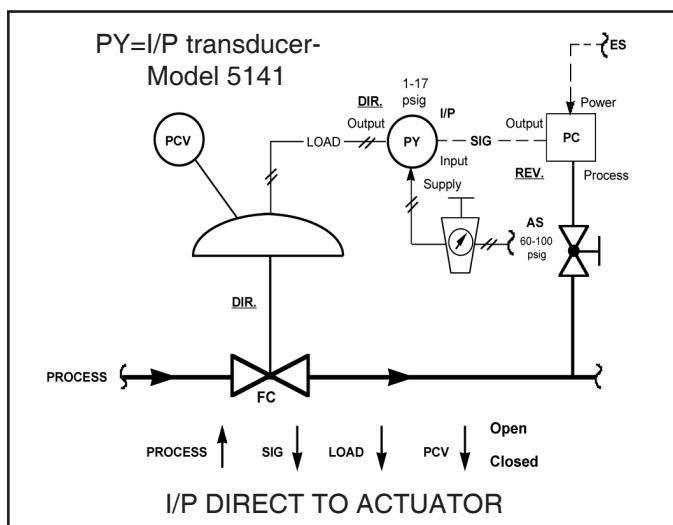
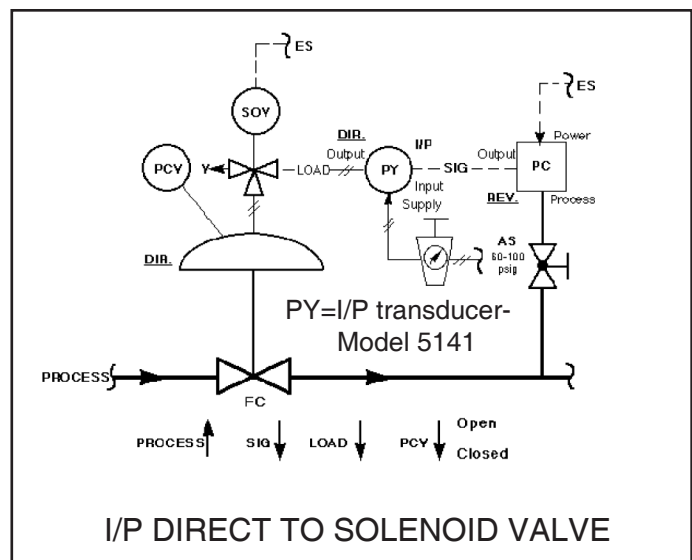
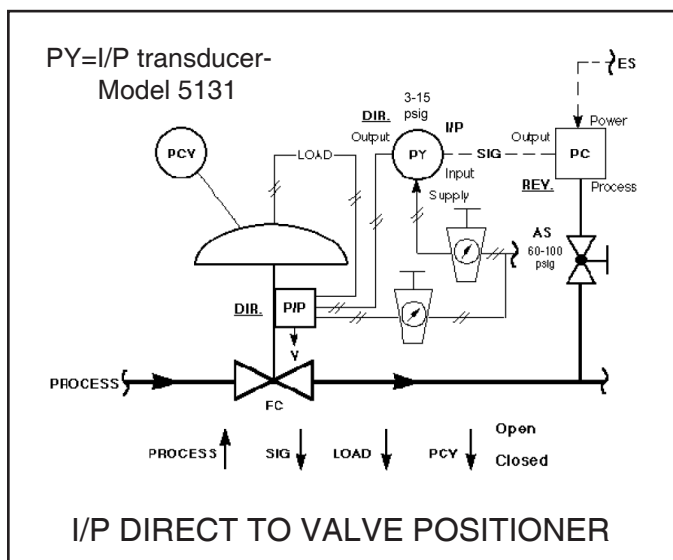

Rotary valve tight shutoff could be compromised with this arrangement. Because of pressure from the transducer, the control valve's actuator pressure is not able to be fully unloaded. Consider using a valve positioner or a solenoid valve if tight shutoff is required.

Reference IPTDP-TB technical bulletin for maximum pressure drop capability of the control valve installed in conjunction with the I/P transducer.

A portion of the mA "SIG" will be lost as the control valve's bench set range is overcome.

NOTE: Use "99" Product Coder to specify model and mounting.