



MODEL 5381 PRESSURE REDUCING REGULATOR



MODEL 5381

NOTE: This valve is not self-draining, and should not be applied for applications requiring clean-in-place (CIP) or steam-in-place (SIP) capability.

The Model 5381 is a stainless steel pressure reducing regulator designed to handle small to mid-capacity flow rates in sanitary biotechnical process piping systems. This unit is capable of controlling outlet pressure to a level between 5 and 200 psig (.34 and 13.8 Barg).

FEATURES

- High Stability:** High mass plug allows dampening of high frequency disturbances from inlet or outlet side of regulator.
- Trim Removal:** Easily removable trim from regulator while in-line.
- Non-Asbestos Construction:** Standard gasketing of non-asbestos material.
- Adjustment Ease:** SST T-bar handle for frequent set point changes.
- Wetted Materials Construction:** All metallic parts are SST. Unit is cleaned to Cashco Spec. # S-1576.
- Surface Finish:** Interior of body surface electro-polished to #32 micro-inch R_a finish with electro-polished exterior.

APPLICATIONS

Used in pharmaceutical industry in production of many health care products for both human and animal consumption. Widely applied for processed food production — candy, beverages, nutritional supplements and artificial sweeteners. May also be used in cosmetics production and specialty chemicals.

Would be found supporting fermenters, batching tanks, cookers, dryers and other similar equipment.

STANDARD/GENERAL SPECIFICATIONS

Body Size and Material: 1/2" (DN15)
Wrought Barstock; ASTM A479, Type 316L SST.

Body Connection: Standard - Sanitary "Tri-Clamp®".
Designed to seal against weld-type clamp liners per ISO 2852.

Spring Chamber Materials: Standard - Cast SST; ASTM A351, Grade CF3M.

Trim:

PART	S1L	SET
Diaphragm	302 SST	EPDM
Diaphragm Cover	-	TFE
Piston	316L SST	316L SST
Seat ¹	316L SST	TFE
Spring	302 SST	302 SST
Pusher Plate	316L SST	316L SST
Body Cap	316L SST	316L SST
Temperature Range °F (°C)	-20 to +400 (-29 to +205)	-20 to +300 (-29 to +149)

¹The fixed portion of the seat is integral to the body. Indicated seat is the moving portion and is attached or integral with the piston.

NOTE: Cashco, Inc. does not recommend metal seated trim on any service where the flow will be dead ended down stream of the pressure reducing regulator. Use composition seat for dead end service.

Gaskets: Standard: TFE Gasket; TFE O-rings at diaphragm and pusher plate locations.

Operating Temperature: -20 to +400°F (-29° to +205°C)

Inlet Pressure: 600 psig (41.3 Barg) maximum

Range Springs & Maximum Pressure Drop: Standard: SST

Range Spring		Recommended Max. Pressure Drop	
psig	(Barg)	psig	(Barg)
5-30	(.34-2.1)	400	(27.6)
20-80	(1.4-5.5)	400	(27.6)
70-140	(4.8-9.6)	400	(27.6)
130-200	(9.0-13.8)	400	(27.6)

Cv's/Capacities: See Tables 1, 2, 3, and 4.

Cleaning: All units cleaned per Cashco Spec. #S-1576.

NOTE: Refer to "TECHNICAL SPECIFICATIONS" tables for a more complete description of the above specifications.

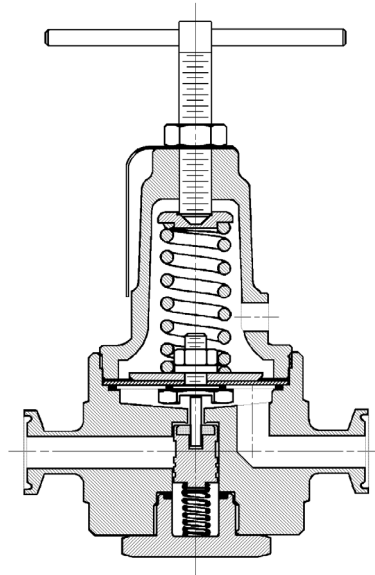

Figure 1: Composition Seat Design

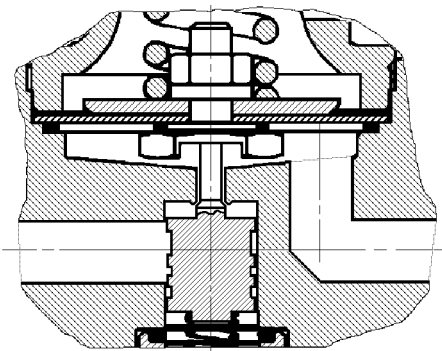

Figure 2: Metal Seat Design

TECHNICAL SPECIFICATIONS

TABLE 1
CAPACITY - Cv
(FL = 0.95)
1/2" Size

OUTLET (P2) PRESSURE (psig)	METAL DIAPHRAGM			COMPOSITION DIAPHRAGM		
	% DROOP			% DROOP		
	10%	20%	30%	10%	20%	30%
10	.05	.09	.15	.13	.22	.35
25	.13	.24	.33	.35	.47	.50
50	.07	.15	.22	.35	.47	.50
75	.12	.23	.32	.45	.50	.50
100	.11	.21	.30	.39	.49	.50
125	.13	.24	.33	.42	.50	.50
150	.10	.19	.28	.38	.48	.50
200	.11	.21	.30	.35	.47	.50

TABLE 2
WATER CAPACITY - GPM
S.G. = 1.0 T - 60°F FL = 0.95
1/2" Size - Composition Diaphragm Only

OUTLET FLOWING PRESSURE (psig)	INLET PRESSURE (psig)	10% Droop	20% Droop	30% Droop	OUTLET FLOWING PRESSURE (psig)	INLET PRESSURE (psig)	10% Droop	20% Droop	30% Droop	
5	50	0.9	1.5	2.3	35	50	1.5	1.9	1.9	
	75	1.1	1.8	2.9		75	2.5	3.1	3.2	
	100	1.3	2.1	3.4		100	3.1	4.0	4.0	
	125	1.4	2.4	3.8		125	3.7	4.6	4.7	
	150	1.6	2.6	4.2		150	4.2	5.3	5.4	
	175	1.7	2.9	4.6		175	4.6	5.8	5.9	
	200	1.8	3.1	4.9		200	5.0	6.3	6.4	
10	50	2.2	3.0	3.2	50	75	1.9	2.4	2.5	
	75	2.8	3.8	4.0		100	2.7	3.4	3.5	
	100	3.3	4.5	4.7		125	3.3	4.2	4.3	
	125	3.8	5.0	5.4		150	3.8	4.8	5.0	
	150	4.1	5.6	5.9		175	4.2	5.4	5.6	
	175	4.5	6.0	6.4		200	4.7	5.9	6.1	
	200	4.8	6.5	6.9		75	100	1.8	2.4	2.5
15	50	2.1	2.8	3.0	125		2.5	3.3	3.5	
	75	2.7	3.6	3.9	150		3.0	4.1	4.3	
	100	3.2	4.3	4.6	175		3.5	4.7	5.0	
	125	3.7	4.9	5.2	200		3.9	5.3	5.6	
	150	4.1	5.5	5.8	100		125	2.0	2.5	2.5
	175	4.4	5.9	6.3			150	2.8	3.5	3.5
	200	4.8	6.4	6.8		175	3.5	4.2	4.3	
25	50	2.3	2.5	2.5		200	4.0	4.9	5.0	
	75	3.2	3.5	3.5		125	150	2.1	2.5	2.5
	100	3.9	4.3	4.3			175	3.0	3.5	3.5
	125	4.5	5.0	5.0			200	3.6	4.3	4.3
	150	5.0	5.6	5.6						
	175	5.5	6.1	6.1						
	200	6.0	6.6	6.6						

TABLE 3
AIR CAPACITY - SCFH
S.G. = 1.0 T - 60°F F_L - 0.95
1/2" Size - Composition Diaphragm Only

OUTLET FLOWING PRESSURE (psig)	INLET PRESSURE (psig)	10% Droop	20% Droop	30% Droop	OUTLET FLOWING PRESSURE (psig)	INLET PRESSURE (psig)	10% Droop	20% Droop	30% Droop
5	25	200	300	500	35	50	700	900	900
	50	300	500	800		75	1200	1500	1500
	75	400	700	1100		100	1600	2000	2000
	100	500	900	1400		150	2300	2900	2900
	150	800	1300	2000		200	3000	3700	3800
	200	1000	1700	2700		300	4400	5500	5600
	300	1500	2500	3900		400	5800	7200	7400
	400	1900	3200	5200		75	1000	1300	1300
10	25	500	600	700	50	100	1500	1800	1900
	50	800	1100	1100		150	2200	2800	2900
	75	1100	1500	1600		200	2900	3600	3800
	100	1400	1900	2000		300	4200	5400	5600
	150	2000	2700	2900	400	5600	7100	7400	
	200	2700	3600	3800	75	100	1100	1400	1500
	300	3900	5300	5600		150	1900	2600	2700
	400	5200	6900	7400		200	2600	3500	3700
25	400	600	600	300		3600	5200	5600	
15	50	800	1100	1100	100	400	5200	6900	7400
	75	1100	1500	1600		150	2000	2400	2400
	100	1400	1900	2000		200	2900	3500	3600
	150	2000	2700	2900		300	4400	5400	5500
	200	2700	3600	3800	400	5900	7200	7400	
	300	3900	5300	5600	500	7300	9000	9200	
	400	5200	6900	7400	150	200	2400	2900	2900
	50	1100	1100	1100		300	4400	5300	5300
75	1400	1600	1600	400		6100	7200	7200	
100	1800	2000	2000	500		7700	9100	9100	
25	150	2600	2900	2900	200	300	3300	4400	4700
	200	3400	3800	3800		400	4900	6600	6900
	300	5000	5600	5600		500	6300	8500	9000
	400	6600	7400	7400					

TABLE 4
STEAM - LBS/HR
S.G. = Actual T = Saturated FL = 0.95
1/2" Size - Metal Diaphragm Only

OUTLET FLOWING PRESSURE (psig)	INLET PRESSURE (psig)	10% Droop	20% Droop	30% Droop	OUTLET FLOWING PRESSURE (psig)	INLET PRESSURE (psig)	10% Droop	20% Droop	30% Droop
5	25	2	3	5	35	50	6	10	15
	50	3	6	9		75	10	17	26
	75	5	8	13		100	14	23	35
	100	6	10	16		125	17	29	43
	125	7	12	20		150	20	34	51
	150	9	15	23		175	23	39	58
	175	10	17	27		200	26	45	67
	200	11	19	30		240	31	53	80
10	25	4	5	8	50	75	10	21	30
	50	7	8	14		100	15	31	44
	75	9	12	20		125	19	40	56
	100	12	15	25		150	22	47	67
	125	15	19	31		175	26	55	77
	150	17	22	36		200	29	62	88
	175	20	25	42		240	35	74	104
	200	23	28	47		75	100	17	32
240	27	33	56	125	24		46	65	
15	25	4	10	14	150		30	58	82
	50	8	19	28	175		36	69	97
	75	12	27	39	200	41	79	111	
	100	15	35	50	240	50	95	133	
	125	19	43	62	100	125	16	36	50
	150	22	51	73		150	23	51	72
	175	25	58	83		175	29	64	90
	200	28	66	94		200	34	76	107
25	240	33	78	111	240	42	93	130	
	50	13	25	30	150	175	19	37	53
	75	20	38	46		200	27	52	76
	100	26	49	59	200	240	38	72	104
	125	31	60	72		240	33	60	83
	150	37	71	85					
	175	43	83	100					
	200	49	94	113					
240	58	111	134						

**TABLE 5
OUTLET PRESSURE LIMIT-
SAFETY RELIEF VALVE SIZING & SETPOINT**

RANGE SPRING (psig)	DIAPHRAGM MATERIAL	EMERGENCY ¹ OVER-PRESSURE (psig)	MAXIMUM Cv WITH VALVE PLUG WIDE OPEN
5-30, 20-80, 70-140, 130-200	ALL	1.5 x UVRS ²	0.5
¹ "Emergency Over-Pressure" is defined as the level of pressure, which if exceeded, may cause internal mechanical damage. ² UVRS - "Upper Value of Range Spring"; i.e. 130-200 psig (9 -13.8 Barg) range spring, value would be 200 psig (13.8 Barg).			

DIMENSIONS AND WEIGHTS

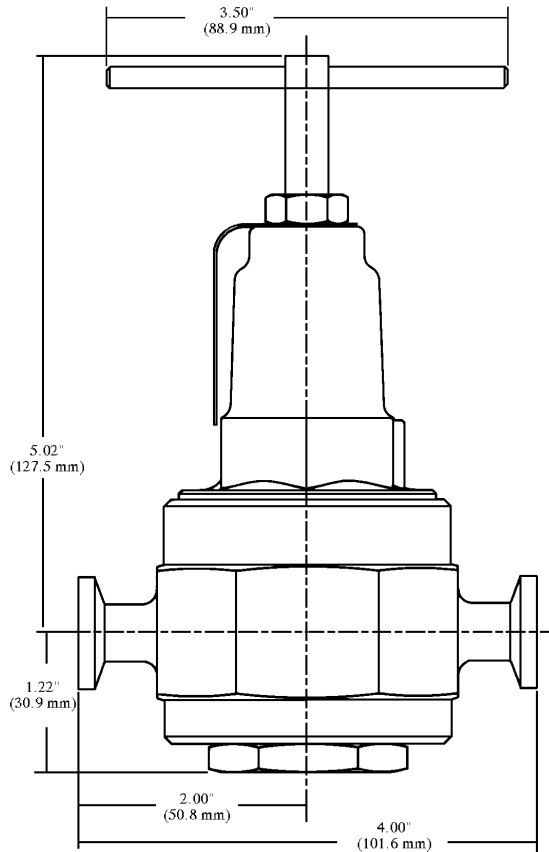

Weight = 4 Lbs.
(1.82 kgs)

NOTES

MODEL 5381 PRODUCT CODE 09/04/07

FOR THE FOOD AND PHARMACEUTICAL INDUSTRY

M**S** **4** – **A** Table 1 **7** – **1** Table 2 **6****0****0****0****0****0****0****B**

TABLE 1 – TRIM DESIGNATION NUMBERS	
Desig.	CODE
S1L*	L1
SET	ST
* Trim utilized on steam service only.	

TABLE 2 – RANGE SPRINGS		
SST Range Spring		CODE
psig	(Barg)	
5-30	(.34-2.1)	A
20-80	(1.4-5.5)	B
70-140	(4.8-9.7)	C
130-200	(9.0-13.8)	D

OPTIONS		
Description	Option	CODE
Wetted Parts Cert 'U' (USP)	Std	6
For Special Construction Other Than Above Contact Cashco for Special Product Code		
1. NUMERIC digits assigned first in "ascending" order. 2. ALPHA designations are assigned second in "alphabetical" order. 3. Left justify. 4. Add "0" to all unused squares. 5. If insufficient quantity of squares, consult factory for proper code.		