



MODEL C-CS “CLEAN STEAM” PRESSURE REDUCING REGULATOR

The Model C-CS* is a 316L SST self-contained pressure reducing regulator designed primarily for steam control in sanitary biotechnological process piping systems. The unit is capable of controlling outlet pressure between 10-75 psig (.69-5.2 Barg) with a maximum inlet pressure of 150 psig (10.3 Barg).



MODEL C-CS

FEATURES

- Dual-guided Plug:** Combines a “winged” guide design directly above the seat and a “non-wetted” guide above the diaphragm.
- Self-Draining:** Angle style body with bottom inlet and side outlet.
- Surface Finish:** Interior of body polished per ASME BPE 1997 (SFV-4 10 micro-inch R_a finish). Interior and exterior surfaces are electropolished.
- Wetted Materials Construction:** 316L SST metallic wetted parts. Unit is cleaned to Cashco Spec. #S-1576.
- Versatility:** Standard pressure reducing regulator or vacuum resistant pressure reducing regulator; metal seat or composition seat.

APPLICATIONS

Used in pharmaceutical industry in production of many health care products for both human and animal consumption. Widely applied for processed food production – candy, beverages, nutritional supplements and artificial sweeteners. May also be used in cosmetics production and specialty chemicals.

Would be found supporting fermenters, batching tanks, cookers, dryers, SIP systems, autoclaves, sterilizers, WFI systems and other similar equipment.

Though designed primarily for “clean steam” service, unit will give satisfactory performance on clean gaseous or liquid applications.

*Patented.

SPECIFICATIONS

Body Connections: Sanitary "Tri-Clamp®". Designed to seal against weld-type clamp liners per ISO 2852. (Lower inlet, side outlet connection.)

Body Size and Material: 3/4", 1", 1-1/2", 2", and 3" (DN20, 25, 40, 50, and 80) sizes. ASTM A182, Gr. F316L; Forged 316L SST for superior quality.

1" (DN25) size only. ASTM A351, Gr. CF3M; Investment Cast 316L SST. Includes reduced orifice as standard construction. See capacity specifications.

See Table 4 for dimensions.

Surface Finish: All wetted surfaces are mechanically polished and electro-polished to a 10 micro-inch R_a finish. Non-wetted exterior surfaces are electro-polished.

Spring Chamber: ASTM A351, Gr. CF8M; Cast 316 SST. Electro-polished.

Body Design Pressure Rating: 150 psig (10.3 Barg); inlet & outlet.

Maximum Operating Temp: 366°F (185°C).

Maximum Allowable Pressure Drop: 90 psid (6.2 Bard) for 10-30 psig (.69-2.1 Barg) range spring.

125 psid (8.6 Bard) for 20-75 psig (1.4-5.2 Barg) range spring.

Minimum Pressure Drop: 3 psid (.21 Bard).

Seat Leakage: Meets ANSI/FCI 70-2.
Metal Seated – Class IV.
Composition Seat – Class VI.

Capacity: Up to 27 Cv. See Table 2 for Cv Capacity vs. Droop.
 See Tables 3A or 3B for Steam Mass Flow vs. Outlet Pressure.

Wetted Trim Materials:

TRIM MATERIAL COMBINATIONS		
PART	METAL	COMPOSITION
	S1L	S36L
Diaphragm	316L SST	316L SST
Stem & Plug	316L SST	316L SST
Seat Disc	N/A	GF-TFE

NOTE: Cashco, Inc. does not recommend metal seated trim on any service where the flow will be dead ended down stream of the pressure reducing regulator. Use composition seat for dead end service.

O-rings: TFE.

Gasket: Expanded PTFE.

Non-Wetted Trim Materials: Castings - CF8M (316 SST).
 Barstock - 18-8 SST.
 All cast parts electro-polished.

Special Cleaning: All units are cleaned per Cashco Spec. #S-1576.

Range Springs: SST material.

psig	(Barg)
10 - 30	(.69 - 2.1)
20 - 75	(1.4 - 5.2)

NOTE: Contact the factory for settings below the lower limit.

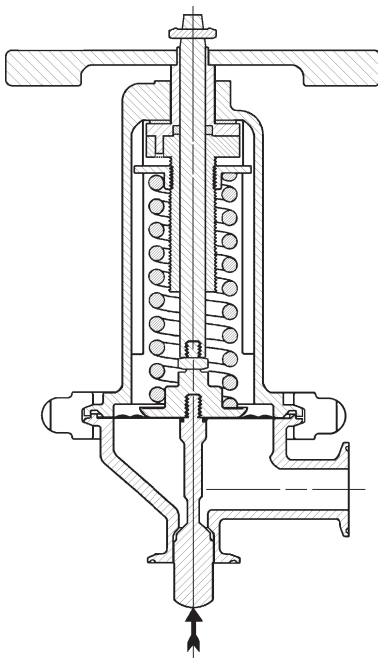

NOTE: The Model C-CS must be installed with the spring chamber in a vertical up orientation.

Refer to IOM-C-CS for complete cleaning procedures and maintenance instructions.

Figure 1: Investment Cast Body

OPTION SPECIFICATIONS

Option-11: DIAPHRAGM RESTRAINT. Utilizes a 316L SST lower diaphragm plate, TFE O-ring, Omniseal and a modified 316L SST plug. Design limits diaphragm deformation when regulator is exposed to vacuum conditions in normal operation sequence. Primarily of importance with autoclaves and sterilizers. See Figure 2.

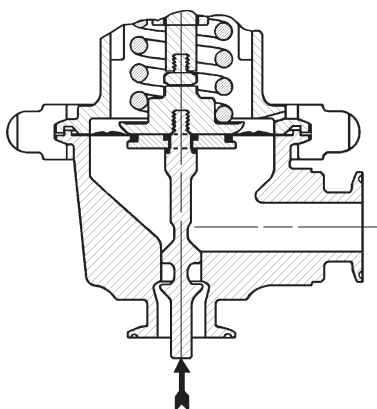

Figure 2: Forged Body with Opt-11

TECHNICAL SPECIFICATIONS

TABLE 1
Maximum Cv with Plug Locked Wide Open
(Use for Relief Valve Sizing and Initial Flow into
an evacuated chamber.)

BODY SIZE		CONFIGURATION (PORT)	Cv
inch	(DN)		
3/4"	(20)	Forged (Full)	2.0
1"	(25)	Investment Cast (Reduced)	3.5
1"	(25)	Forged (Full)	6.0
1-1/2"	(40)	Forged (Reduced)	10.0
1-1/2"	(40)	Forged (Full)	12.0
2"	(50)	Forged (Full)	19.0
3"	(80)	Forged (Full)	27.0

TECHNICAL SPECIFICATIONS

TABLE 2
Cv CAPACITY vs. DROOP
F_L = 0.85

RANGE SPRING 10-30 psig (.69-2.1 Barg)																						
Set Pressure		3/4" (DN20) Full Port Droop			1" (DN25) Reduced Port Droop			1" (DN25) Full Port Droop			1-1/2" (DN40) Reduced Port Droop			1-1/2" (DN40) Full Port Droop			2" (DN50) Full Port Droop			3" (DN80) Full Port Droop		
		10%	20%	30%	10%	20%	30%	10%	20%	30%	10%	20%	30%	10%	20%	30%	10%	20%	30%	10%	20%	30%
psig	(Barg)	10%	20%	30%	10%	20%	30%	10%	20%	30%	10%	20%	30%	10%	20%	30%	10%	20%	30%	10%	20%	30%
10	(.69)	.24	.39	.63	.55	.93	1.37	.90	1.56	2.09	.65	.88	1.34	1.09	2.17	3.26	2.08	4.17	6.25	2.56	5.13	7.69
15	(1.0)	.31	.65	1.11	.58	1.22	1.88	1.43	2.15	2.94	.68	1.12	1.66	1.56	3.13	4.69	2.88	5.77	8.65	3.49	6.98	10.47
20	(1.4)	.45	1.03	1.40	1.03	1.80	2.40	1.80	2.98	3.67	.84	1.43	2.07	2.00	4.00	6.00	3.57	7.14	10.71	4.26	8.51	12.77
25	(1.7)	.50	1.37	2.00	1.03	1.92	2.56	2.22	3.57	4.26	.91	1.66	2.45	2.40	4.81	7.21	4.17	8.33	12.50	4.90	9.80	14.71
30	(2.1)	.65	1.61	2.00	1.44	2.35	2.88	2.61	4.08	5.39	.97	1.84	2.78	2.78	5.56	8.33	4.69	9.38	14.06	5.45	10.91	16.36
RANGE SPRING 20-75 psig (1.4-5.2 Barg)																						
Set Pressure		3/4" (DN20) Full Port Droop			1" (DN25) Reduced Port Droop			1" (DN25) Full Port Droop			1-1/2" (DN40) Reduced Port Droop			1-1/2" (DN40) Full Port Droop			2" (DN50) Full Port Droop			3" (DN80) Full Port Droop		
		10%	20%	30%	10%	20%	30%	10%	20%	30%	10%	20%	30%	10%	20%	30%	10%	20%	30%	10%	20%	30%
psig	(Barg)	10%	20%	30%	10%	20%	30%	10%	20%	30%	10%	20%	30%	10%	20%	30%	10%	20%	30%	10%	20%	30%
20	(1.4)	.25	.55	.86	.42	.63	1.02	.63	1.25	1.93	.76	1.27	1.83	1.34	2.67	4.01	2.44	4.88	7.32	2.94	5.88	8.82
25	(1.7)	.35	.78	1.10	.49	.84	1.38	.68	1.37	2.14	.79	1.49	1.96	1.63	3.25	4.88	2.91	5.82	8.73	3.47	6.94	10.41
30	(2.1)	.44	.92	1.29	.59	1.08	1.73	.73	1.49	2.35	.87	1.50	2.24	1.90	3.81	5.71	3.34	6.67	10.01	3.94	7.89	11.83
35	(2.4)	.60	1.12	1.59	.64	1.28	1.96	.78	1.61	2.56	1.00	1.87	2.67	2.16	4.33	6.49	3.73	7.45	11.18	4.37	8.74	13.12
40	(2.8)	.64	1.25	1.71	.71	1.48	2.18	.83	1.73	2.77	1.03	1.88	2.70	2.41	4.83	7.24	4.08	8.17	12.25	4.76	9.52	14.28
45	(3.1)	.68	1.31	1.81	.76	1.59	2.36	.88	1.85	2.98	1.45	2.24	3.07	2.65	5.30	7.96	4.42	8.83	13.25	5.11	10.22	15.33
50	(3.4)	.88	1.54	2.00	.89	1.81	2.48	.93	1.97	3.18	1.52	2.37	3.43	2.88	5.76	8.64	4.72	9.44	14.16	5.43	10.86	16.29
55	(3.8)	.90	1.60	2.00	.92	1.85	2.68	.98	2.09	3.39	1.59	2.42	3.52	3.10	6.19	9.29	5.00	10.01	15.01	5.73	11.45	17.18
60	(4.1)	.94	1.70	2.00	.98	1.91	2.69	1.03	2.21	3.60	1.63	2.62	3.68	3.30	6.61	9.91	5.27	10.53	15.80	6.00	11.99	17.99
65	(4.5)	.96	1.78	2.00	1.04	2.11	2.84	1.08	2.33	3.81	1.66	2.67	3.84	3.50	7.00	10.50	5.51	11.02	16.54	6.25	12.49	18.74
70	(4.8)	.99	1.84	2.00	1.09	2.19	2.94	1.13	2.45	4.02	1.68	2.71	3.92	3.69	7.38	11.07	5.74	11.48	17.22	6.48	12.96	19.43
75	(5.2)	1.12	1.94	2.00	1.14	2.31	3.00	1.18	2.58	4.23	1.71	2.76	4.07	3.87	7.74	11.62	5.96	11.91	17.87	6.69	13.39	20.08

TABLE 3A
STEAM MASS FLOW – lb/hr vs. OUTLET PRESSURE
10-30 psig (.69-2.1 Barg) Range Spring
S.G. Actual T = Saturated F_L = 0.85

P2 - OUTLET PRESSURE		P1 - INLET PRESSURE		3/4" (DN20) Full Port					1" (DN25) Reduced Port					1" (DN25) Full Port				
				DROOP			Qmax	P2 @ Qmax	DROOP			Qmax	P2 @ Qmax	DROOP			Qmax	P2 @ Qmax
				10%	20%	30%			10%	20%	30%			10%	20%	30%		
psig	(Barg)	psig	(Barg)	10%	20%	30%	Qmax	P2 @ Qmax	10%	20%	30%	Qmax	P2 @ Qmax	10%	20%	30%	Qmax	P2 @ Qmax
10	(.69)	25	(1.7)	14	23	38	123	-1.6	33	56	83	215	-0.3	53	94	127	369	-4.1
		50	(3.4)	24	39	62	198	-1.6	54	92	136	346	-0.3	89	154	207	594	-4.1
		75	(5.2)	33	53	86	272	-1.6	75	126	186	476	-0.3	122	212	284	652	-0.7
15	(1.0)	25	(1.7)	17	37	65	122	6.2	32	69	109	214	5.0	78	122	171	369	1.8
		50	(3.4)	31	64	110	198	6.2	57	121	186	346	5.0	141	213	291	594	1.8
		75	(5.2)	42	88	151	272	6.2	79	166	255	476	5.0	194	292	399	815	1.8
20	(1.4)	25	(1.7)	21	52	76	119	9.1	48	91	130	209	8.5	83	151	198	369	3.9
		50	(3.4)	44	102	138	198	9.1	101	178	237	346	8.5	177	294	363	594	3.9
		75	(5.2)	61	140	190	272	9.1	140	245	326	476	8.5	245	405	499	815	3.9
25	(1.7)	50	(3.4)	48	134	197	197	17.5	99	187	252	346	12.0	214	348	419	594	8.0
		75	(5.2)	68	186	272	272	17.5	140	261	348	476	12.0	302	485	579	815	8.0
		100	(6.9)	86	236	345	345	17.5	178	331	442	604	12.0	383	616	735	1036	8.0
30	(2.1)	50	(3.4)	60	154	194	194	21.0	134	224	280	346	15.7	243	389	524	588	18.9
		75	(5.2)	88	219	272	272	21.0	195	319	391	476	15.7	354	554	732	815	18.9
		100	(6.9)	112	278	345	345	21.0	249	406	497	604	15.7	451	704	930	1036	18.9

Metric Conversion Factors: Cv / 1.16 = kv; lb/hr x 0.4536 = kg/hr

TABLE 3A, cont.
STEAM MASS FLOW – lb/hr vs. OUTLET PRESSURE
10-30 psig (.69-2.1 Barg) Range Spring
S.G. Actual T = Saturated F_L = 0.85

P2 - OUTLET PRESSURE		P1 - INLET PRESSURE		1-1/2" (DN40) Reduced Port					1-1/2" (DN40) Full Port				
psig	(Barg)	psig	(Barg)	DROOP			Qmax	P2 @ Qmax	DROOP			Qmax	P2 @ Qmax
				10%	20%	30%			10%	20%	30%		
10	(1.0)	25	(1.7)	39	53	81	369	-8.2	65	130	197	739	-5.0
		50	(3.4)	64	87	133	594	-8.2	108	215	323	1187	-5.0
		75	(5.2)	88	120	182	815	-8.2	148	295	443	1304	-1.7
15	(1.0)	25	(1.7)	37	63	97	369	-7.6	85	177	273	739	0.0
		50	(3.4)	67	111	164	594	-7.6	154	310	464	1187	0.0
		75	(5.2)	92	152	226	815	-7.6	212	425	637	1630	0.0
20	(1.4)	25	(1.7)	39	72	112	369	-4.4	92	202	324	735	5.0
		50	(3.4)	83	141	205	594	-4.4	197	395	594	1187	5.0
		75	(5.2)	114	194	281	815	-4.4	272	543	815	1630	5.0
25	(1.7)	50	(3.4)	88	162	241	791	-8.8	231	469	710	1187	10.0
		75	(5.2)	124	226	333	815	0.7	326	654	990	1630	10.0
		100	(6.9)	157	287	423	1036	0.7	414	830	1245	2072	10.0
30	(2.1)	50	(3.4)	90	176	270	791	-4.0	258	530	809	1186	15.0
		75	(5.2)	132	250	378	1087	-4.0	377	755	1132	1630	15.0
		100	(6.9)	167	318	480	1381	-4.0	480	960	1438	2072	15.0

P2 - OUTLET PRESSURE		P1 - INLET PRESSURE		2" (DN50) Full Port					3" (DN80) Reduced Port				
psig	(Barg)	psig	(Barg)	DROOP			Qmax	P2 @ Qmax	DROOP			Qmax	P2 @ Qmax
				10%	20%	30%			10%	20%	30%		
10	(1.0)	25	(1.7)	124	250	378	1170	-2.2	152	308	466	1662	-4.3
		50	(3.4)	206	413	618	1880	-2.2	253	508	761	2671	-4.3
		75	(5.2)	283	567	849	2581	-2.2	348	697	1045	3668	-4.3
15	(1.0)	25	(1.7)	158	327	503	1170	2.4	191	395	609	1662	-0.2
		50	(3.4)	285	571	856	1880	2.4	345	691	1036	2671	-0.2
		75	(5.2)	391	784	1175	2581	2.4	474	948	1423	3668	-0.2
20	(1.4)	25	(1.7)	165	361	578	1150	7.0	197	430	690	1659	4.0
		50	(3.4)	351	705	1059	1880	7.0	419	840	1263	2671	4.0
		75	(5.2)	485	970	1455	2581	7.0	579	1156	1735	3668	4.0
25	(1.7)	50	(3.4)	402	813	1230	1880	11.7	472	956	1448	2671	8.1
		75	(5.2)	567	1132	1698	2581	11.7	666	1331	1999	3668	8.1
		100	(6.9)	720	1438	2158	3280	11.7	846	1692	2539	4661	8.1
30	(2.1)	50	(3.4)	436	895	1366	1875	16.3	506	1041	1589	2671	12.2
		75	(5.2)	636	1274	1910	2581	16.3	740	1482	2223	3668	12.2
		100	(6.9)	810	1619	2427	3280	16.3	941	1883	2824	4661	12.2

TABLE 3B
STEAM MASS FLOW – lb/hr vs. OUTLET PRESSURE
20-75 psig (1.4-5.2 Barg) Range Spring
S.G. Actual T = Saturated F_L = 0.85

P2 - OUTLET PRESSURE		P1 - INLET PRESSURE		3/4" (DN20) Full Port				1" (DN25) Reduced Port					1" (DN25) Full Port					
psig	(Barg)	psig	(Barg)	DROOP			Qmax	P2 @ Qmax	DROOP			Qmax	P2 @ Qmax	DROOP			Qmax	P2 @ Qmax
				10%	20%	30%			10%	20%	30%			10%	20%	30%		
20	(1.4)	25	(1.7)	12	28	46	123	3.0	19	32	55	215	-5.1	29	63	104	369	-4.0
		50	(3.4)	25	54	85	198	3.0	41	62	101	346	-5.1	62	123	191	594	-4.0
		75	(5.2)	34	75	117	272	3.0	57	86	139	476	-5.1	86	170	262	652	1.3
		100	(6.9)	43	95	148	345	3.0	73	109	176	604	-5.1	109	216	333	829	1.3
		125	(8.6)	52	115	180	418	3.0	88	132	213	586	0.3	132	262	404	1004	1.3
25	(1.7)	50	(3.4)	34	76	108	198	7.0	47	82	136	346	2.8	66	134	211	594	-1.3
		75	(5.2)	48	106	149	272	7.0	67	114	187	476	2.8	92	186	291	815	-1.3
		100	(6.9)	60	135	190	345	7.0	85	145	238	604	2.8	117	236	369	829	4.6
		125	(8.6)	73	163	230	418	7.0	103	176	289	732	2.8	142	287	448	1004	4.6
		150	(10.3)	86	192	270	492	7.0	120	206	339	860	2.8	167	337	526	1180	4.6
30	(2.1)	50	(3.4)	41	88	125	198	12.4	55	103	168	346	8.8	68	142	228	594	1.9
		75	(5.2)	60	125	175	272	12.4	80	147	235	476	8.8	99	202	319	815	1.9
		100	(6.9)	76	159	223	345	12.4	102	186	299	604	8.8	126	257	406	1036	1.9
		125	(8.6)	92	193	270	418	12.4	123	226	362	732	8.8	153	312	492	1004	8.2
40	(2.8)	150	(10.3)	108	226	317	492	12.4	145	265	425	860	8.8	179	366	578	1180	8.2
		50	(3.4)	51	109	157	190	24.2	57	129	200	345	16.7	66	150	255	594	9.4
		75	(5.2)	85	168	232	272	24.2	94	199	296	476	16.7	110	233	375	815	9.4
		100	(6.9)	110	216	295	345	24.2	123	255	376	604	16.7	143	299	478	1036	9.4
		125	(8.6)	134	262	358	418	24.2	149	310	456	732	16.7	174	362	580	1255	9.4
50	(3.4)	150	(10.3)	157	307	420	492	24.2	175	364	536	860	16.7	204	425	681	1475	9.4
		75	(5.2)	111	201	267	267	35.0	112	236	331	476	23.6	117	257	424	815	17.5
		100	(6.9)	150	265	345	345	35.0	152	312	428	604	23.6	159	339	549	1036	17.5
		125	(8.6)	184	322	418	418	35.0	186	379	519	732	23.6	195	412	665	1255	17.5
		150	(10.3)	216	379	492	492	35.0	219	445	610	860	23.6	229	484	782	1475	17.5
60	(4.1)	75	(5.2)	106	208	257	257	42.0	111	233	346	470	32.7	116	270	463	815	26.5
		100	(6.9)	156	289	344	344	42.0	163	324	462	604	32.7	171	375	619	1036	26.5
		125	(8.6)	196	356	418	418	42.0	204	400	563	732	32.7	215	462	753	1255	26.5
		150	(10.3)	231	418	492	492	42.0	241	469	661	860	32.7	253	543	885	1475	26.5
70	(4.8)	75	(5.2)	90	201	242	242	49.0	99	239	355	453	41.2	103	267	486	798	35.8
		100	(6.9)	157	303	339	339	49.0	172	361	498	602	41.2	179	404	681	1036	35.8
		125	(8.6)	203	382	418	418	49.0	224	455	615	732	41.2	232	509	841	1255	35.8
		150	(10.3)	243	452	492	492	49.0	267	538	723	860	41.2	277	602	988	1475	35.8
75	(5.2)	100	(6.9)	171	313	335	335	52.5	174	373	502	599	44.4	180	416	708	1033	40.4
		125	(8.6)	227	401	417	417	52.5	231	477	626	732	44.4	239	533	883	1255	40.4
		150	(10.3)	274	477	492	492	52.5	279	567	737	860	44.4	288	634	1040	1475	40.4

Metric Conversion Factor: lb/hr x 0.4536 = kg/hr

TABLE 3B, cont.
STEAM MASS FLOW – lb/hr vs. OUTLET PRESSURE
(20-75 psig (1.4-5.2 Barg) Range Spring)
S.G. Actual T = Saturated F_L = 0.85

P2 - OUTLET PRESSURE		P1 - INLET PRESSURE		1-1/2" (DN40) Reduced Port					1-1/2" (DN40) Full Port				
psig	(Barg)	psig	(Barg)	DROOP			Qmax	P2 @ Qmax	DROOP			Qmax	P2 @ Qmax
				10%	20%	30%			10%	20%	30%		
20	(1.4)	25	(1.7)	35	64	99	369	-8.3	62	135	217	739	-3.9
		50	(3.4)	75	125	181	594	-8.3	132	264	397	1187	-3.9
		75	(5.2)	103	173	249	815	-8.3	182	363	545	1630	-3.9
		100	(6.9)	131	219	316	863	-3.0	231	461	692	1657	1.5
		125	(8.6)	159	266	383	1046	-3.0	280	559	839	2009	1.5
25	(1.7)	50	(3.4)	76	145	193	495	-6.8	157	317	480	1187	1.1
		75	(5.2)	107	202	266	679	-6.8	221	442	663	1630	1.1
		100	(6.9)	136	257	338	863	-6.8	281	561	842	2072	1.1
		125	(8.6)	165	312	410	1046	-6.8	341	680	1021	2511	1.1
		150	(10.3)	194	366	482	1229	-6.8	401	799	1199	2360	6.6
30	(2.1)	50	(3.4)	81	143	218	594	-1.9	177	363	555	1187	6.1
		75	(5.2)	118	204	304	815	-1.9	258	518	776	1630	6.1
		100	(6.9)	150	259	387	1036	-1.9	328	658	986	2072	6.1
		125	(8.6)	182	314	469	1255	-1.9	398	797	1195	2511	6.1
		150	(10.3)	214	369	551	1475	-1.9	467	936	1403	2949	6.1
40	(2.8)	50	(3.4)	82	163	248	594	3.9	193	420	665	1184	16.2
		75	(5.2)	137	253	366	815	3.9	320	650	981	1630	16.2
		100	(6.9)	178	325	466	1036	3.9	416	834	1250	2072	16.2
		125	(8.6)	216	393	565	1255	3.9	504	1011	1515	2511	16.2
		150	(10.3)	253	462	664	1475	3.9	592	1187	1780	2949	16.2
50	(3.4)	75	(5.2)	191	309	457	1087	2.7	362	750	1152	1629	26.3
		100	(6.9)	260	408	592	1381	2.7	492	992	1491	2072	26.3
		125	(8.6)	318	496	718	1674	2.7	603	1205	1808	2511	26.3
		150	(10.3)	374	583	843	1966	2.7	708	1416	2124	2949	26.3
		75	(5.2)	184	320	473	1087	5.3	372	807	1275	1592	36.3
60	(4.1)	100	(6.9)	271	445	632	1381	5.3	549	1122	1703	2071	36.3
		125	(8.6)	340	548	770	1674	5.3	688	1383	2074	2511	36.3
		150	(10.3)	401	644	905	1966	5.3	811	1625	2436	2949	36.3
		75	(5.2)	153	295	474	1359	-3.8	336	804	1338	1490	46.4
		100	(6.9)	266	447	664	1726	-3.8	584	1217	1874	2046	46.4
70	(4.8)	125	(8.6)	345	563	820	1674	13.6	757	1534	2315	2511	46.4
		150	(10.3)	412	666	964	1966	13.6	905	1814	2721	2949	46.4
		100	(6.9)	261	445	681	1726	1.6	590	1249	1945	2016	51.4
		125	(8.6)	347	570	849	2092	1.6	784	1598	2424	2506	51.4
		150	(10.3)	418	678	1000	2458	1.6	946	1901	2856	2949	51.4
P2 - OUTLET PRESSURE	P1 - INLET PRESSURE	2" (DN50) Full Port					3" (DN80) Full Port						
		DROOP			Qmax	P2 @ Qmax	DROOP			Qmax	P2 @ Qmax		
psig	(Barg)	psig	(Barg)	10%			20%	30%	10%			20%	30%
20	(1.4)	25	(1.7)	113	247	395	1170	-0.4	136	297	476	1662	-4.6
		50	(3.4)	240	482	724	1880	-0.4	289	580	872	2671	-4.6
		75	(5.2)	332	663	995	2581	-0.4	399	799	1198	3668	-4.6
		100	(6.9)	421	842	1264	3280	-0.4	508	1015	1523	4661	-4.6
		125	(8.6)	511	1021	1532	3181	4.3	615	1230	1846	5650	-4.6
25	(1.7)	50	(3.4)	280	568	859	1880	4.3	334	677	1025	2671	-0.4
		75	(5.2)	395	791	1186	2581	4.3	471	943	1414	3668	-0.4
		100	(6.9)	502	1005	1507	3280	4.3	599	1198	1797	4661	-0.4
		125	(8.6)	609	1218	1827	3976	4.3	726	1452	2178	5650	-0.4
		150	(10.3)	715	1431	2146	4670	4.3	853	1706	2559	6636	-0.4
30	(2.1)	50	(3.4)	310	636	973	1880	8.9	366	753	1149	2671	3.7
		75	(5.2)	453	906	1360	2581	8.9	535	1072	1607	3668	3.7
		100	(6.9)	577	1151	1728	3280	8.9	680	1362	2042	4661	3.7
		125	(8.6)	699	1396	2095	3976	8.9	824	1651	2475	5650	3.7
		150	(10.3)	821	1639	2460	4670	8.9	968	1939	2908	6636	3.7
40	(2.8)	50	(3.4)	326	710	1126	1867	18.1	381	827	1313	2671	12.0
		75	(5.2)	542	1099	1661	2581	18.1	632	1281	1936	3668	12.0
		100	(6.9)	704	1410	2115	3280	18.1	822	1643	2465	4661	12.0
		125	(8.6)	854	1710	2563	3976	18.1	996	1992	2988	5650	12.0
		150	(10.3)	1003	2008	3011	4670	18.1	1170	2340	3510	6636	12.0
50	(3.4)	75	(5.2)	593	1229	1888	2577	27.3	683	1414	2172	3668	20.2
		100	(6.9)	807	1626	2444	3280	27.3	928	1870	2812	4661	20.2
		125	(8.6)	988	1975	2963	3976	27.3	1136	2272	3409	5650	20.2
		150	(10.3)	1160	2320	3480	4670	27.3	1335	2669	4004	6636	20.2
		75	(5.2)	595	1286	2032	2518	36.5	677	1465	2314	3658	28.5
60	(4.1)	100	(6.9)	877	1788	2715	3279	36.5	998	2036	3091	4661	28.5
		125	(8.6)	1098	2203	3306	3976	36.5	1250	2508	3764	5650	28.5
		150	(10.3)	1295	2588	3884	4670	36.5	1475	2947	4422	6636	28.5
		75	(5.2)	523	1251	2081	2373	45.7	591	1413	2348	3575	36.7
		100	(6.9)	908	1893	2916	3243	45.7	1025	2137	3290	4659	36.7
70	(4.8)	125	(8.6)	1178	2386	3601	3976	45.7	1330	2694	4063	5650	36.7
		150	(10.3)	1408	2822	4233	4670	45.7	1590	3185	4776	6636	36.7
		100	(6.9)	909	1922	2991	3204	50.4	1020	2161	3361	4646	40.9
		125	(8.6)	1208	2460	3728	3970	50.4	1356	2765	4190	5650	40.9
		150	(10.3)	1457	2926	4392	4670	50.4	1635	3289	4935	6636	40.9

Metric Conversion Factor: lb/hr x 0.4536 = kg/hr

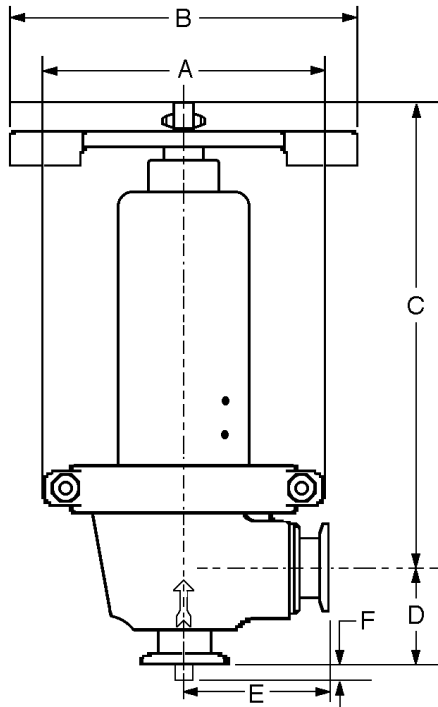

Figure 3:
Forged Body
Model C-CS

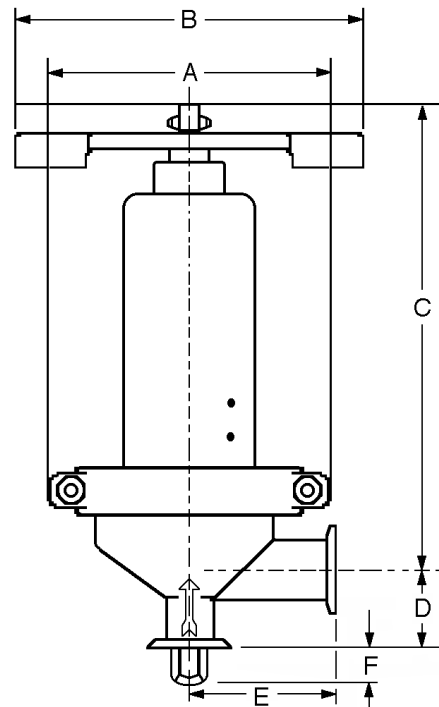

Figure 4:
Investment Cast Body
Model C-CS

TABLE 4
DIMENSIONS

ENGLISH UNITS							
Regulator Size Inches	FORGED BODY-inch						Ship Weight lb
	A	B	C	D	E	F	
3/4"	7.50	8.00	10.13	2.00	3.31	0.32	22
1" (Full)	7.50	8.00	10.15	2.00	3.31	0.38	22
1-1/2" (Reduced)	7.50	8.00	10.15	2.00	3.31	0.44	22
1-1/2" (Full)	9.50	8.00	12.79	2.60	4.50	0.44	35
2"	9.50	8.00	12.79	2.60	4.50	0.57	35
3"	9.50	8.00	13.38	2.57	4.50	0.75	42
INVESTMENT CAST BODY							
1" (Reduced)	7.75	8.00	9.94	2.00	3.31	0.94	15
METRIC UNITS							
Regulator Size (DN)	FORGED BODY-mm						Ship Weight kg
	A	B	C	D	E	F	
(20)	190	203	257	50	84	8	9.9
(25) (Full)	190	203	258	50	84	10	9.9
(40) (Reduced)	190	302	258	50	84	11	9.9
(40) (Full)	241	203	325	66	114	11	15.8
(50)	241	203	325	66	114	14	15.8
(80)	241	203	340	65	114	19	19.0
INVESTMENT CAST BODY							
DN25 (Reduced)	190	203	252	50	84	24	6.8

MODEL C-CS PRODUCT CODE

10/01/07



TABLE 1 - SIZE			
Port	Size		CODE
	in	(DN)	
Full	3/4"	(20)	5
Full	1"	(25)	F
Reduced	1" *	(25)*	6
Reduced	1-1/2"	(40)	8
Full	1-1/2"	(40)	G
Full	2"	(50)	9
Full	3"	(80)	B

* Must select 316L Investment Cast Body from Table 2

TABLE 2 - BODY / SPRING CHAMBER MATERIALS		
SST Body / Spring Chamber	Body Sizes	CODE
316L Forged Body / 316 Investment Cast	All	F
316L Investment Cast / 316 Investment Cast	1" (DN25) w/ reduced port only	M

TABLE 3 - TRIM DESIGNATION		
Desig.	Available Certs	CODE
SL1 *	'U' Only	SL
S36L ** √	'STD' Only	6L

* For Table 6 Select Code "6"
 ** For Table 6 Select Code "F"
 √ Not available for Investment Cast Body

TABLE 4 - Product Classification Under European "Pressure Equipment Directive"		
PRODUCT	HAZARD CATEGORY	CODE
Standard	N/A	7
EUROPEAN ¹ Consult Factory for Special Code (PED does not apply to DN25 and below)	Sound Engineering Practice (SEP)	S
	CE Marked Hazard Cat I or II	E

¹ For products to be placed in service in Europe (See Cashco Spec. # 7E13)

TABLE 5 - SST RANGE SPRING		
psig	(Barg)	CODE
10 - 30	(.69 - 2.1)	1
20 - 75	(1.4 - 5.2)	2

TABLE 6 - OPTIONS		
DESCRIPTION	OPTION	CODE
Diaphragm Restraint	-11	2
Wetted Parts Cert 'U' (USP)	-	6
Wetted Parts Cert 'STD' (Chemical & Physical)	-	F

For Special Construction Other Than Above Contact Cashco for Special Product Code

1. NUMERIC digits assigned first in "ascending" order.
2. ALPHA designations are assigned second in "alphabetical" order.
3. Left justify.
4. Add "0" to all unused squares.
5. If insufficient quantity of squares, consult factory for proper code.