



MODEL HP-1+6+S

# MODEL HP-1+6+S

## "HIGH" PRESSURE DIFFERENTIAL REDUCING REGULATOR

Model "HP-1+6+S" is a heavy duty, high pressure reducing differential regulator. The internal trim is of a pressure balanced design, with the diaphragm having both up and down stops. Inlet pressure may be as high as 3000 psig (207 Barg). Outlet pressure may be as high as 1500 psig (103 Barg). Differential pressures may vary from 15-150 psid (1.0-10.3 Bard).

### ⚠ CAUTION

HP 1+6+S Option contains single diaphragm construction. In the event of diaphragm failure, the process fluid will mix with the loading fluid.

### FEATURES

- High pressure operation.
- CS and SST body/spring chamber materials.
- NACE or Non-NACE constructions.
- Anti-blowout adjusting screw assembly with closing cap.
- Standard non-asbestos gaskets

### APPLICATIONS

Most commonly applied to develop a constant differential pressure across a rotating shaft seal to provide proper sealing and lubricating conditions over varying pressure ranges.

For gaseous and non-flashing, non-cavitating liquid services.

### ⚠ CAUTION

Do NOT Apply in Steam Service!

Do NOT Apply in Oxygen Service!

### STANDARD/GENERAL SPECIFICATIONS

**Body Sizes:** 1/2", 3/4", 1, 1-1/2"  
(DN15, 20, 25, 40)

**End Connections:** Std. – NPT.  
Opt-30 – Welded-on RF flanges; pressure classes 600#, 900#, 1500#.

**Body/Spring Chamber/Spacer Materials:** CS/CS/CS or SST/SST/SST.  
CS = Carbon Steel  
SST = Stainless Steel

**Inlet Pressure:** Up to 3000 psig (207 Barg). May be limited by end connection.



**Outlet Pressure:** Up to 1500 psig (103 Barg). May be limited by end connection.

**Temperature Range:** -20° to +400°F (-29° to +205°C).

**Maximum Pressure Drop:** Liquid – 600 psig (41.4 Bard). Gas – 1500 psig (103 Bard).

**Differential Pressure Range:** 15-150 psid (1.0-10.3 Bard) with multiple range springs.

Body Size		Diff. Pressure Range	
inch	(DN)	psid	(Bard)
1/2", 3/4" & 1"	(15, 20, & 25)	15 - 40	(1.0-2.8)
		30 - 150	(2.1-10.3)
1-1/2"	(40)	30 - 100	(2.1-6.9)
		80 - 150	(5.5-10.3)

**Capacity:** Up to 4.40 Cv.

**Internal Valve Trim:** Design is pressure-balanced.  
Composition Seat – Trim Designation No. S40T.  
Temp Range: -20° to +400°F (-29° to 205°C)

Materials –  
Piston and Cylinder –316 SST.  
Diaphragm and Quad Ring – Fluorocarbon elastomer.  
Seat and Backup Ring – TFE.  
Piston Spring –  
Nace - Inconel X-750  
Non-Nace - 302 SST

**Gaskets/Seals:** Std. – Non-asbestos.  
Cylinder Gskt. – Graphite/NBR.  
O-rings – Fluorocarbon Elastomer (FKM).  
Backup Rings – PTFE-split.

**Flange Bolting:** All bolting is alloy steel, zinc plated.  
Studs: ASTM A-193, Gr. B7.  
Nuts: ASTM A-194, Gr. 2H.  
Cap Screws: ASTM A-193, Gr. B7.  
Note: All studs are elongated to allow bracket mounting; bracket supplied by customer.

**Body Cap:** ASTM A479, S31600, Annealed.

**Miscellaneous Internals Materials:**  
Spring Chamber Zone –  
Closing Cap – 316 SST.  
Adj. Screw Jam Nut – 316 SST.  
Adj. Screw – 17-4 PH SST.  
Adj. Screw Housing\* – 316 SST.  
Pressure Plate -  
Std. – Sizes 1/2"–1" (DN15-25) – 316 SST.  
Size 1-1/2" (DN40) – CS with CS body; SST with SST body.  
Opt-40 – 316 SST, all sizes.  
Spring Button -  
Std. – CS body, All sizes except 1-1/2" (DN40) – CS.  
CS body 1-1/2" (DN40) – Brass.  
SST body – SST.  
Opt-40 – All sizes, all body materials – SST.  
Range Spring – Epoxy coated if CS.  
Std. – CS body – Steel.  
SST body – Inconel X-750.  
Opt-40 – Inconel X-750.

\*Welded to spring chamber.

Body Zone –  
Pusher Plate – 316 SST.

**Painting:** Standard: All non-corrosion resistant portions to be painted with corrosion resistant epoxy paint per Cashco Spec #S-1606.

## OPTION SPECIFICATIONS

**Option -30:** FLANGED END CONNECTIONS.  
Welded-on pressure classes 600#, 900# or 1500# raised face flanges for CS or SST bodies. Pipe nipples and flanges of same basic materials as body. Pipe nipples are seal welded after screwing into body; flanges are socket welded to pipe nipples. Flange pressure class is same for inlet and outlet.

With 900# and 1500# flanges, the outlet pressure rating is limited by the body's rating. For 600# flanges, the outlet pressure rating is limited by the flange's rating. **See Table 2.**

All welding procedures in compliance with ASME Boiler & Pressure Vessel Code, Section IX, and American Petroleum Institute API-614 requirements.

**Option -40:** NACE CONSTRUCTION. For applications where gas or liquid is classified as “sour” due to presence of H<sub>2</sub>S. Both CS and SST body/spring chamber constructions available to meet NACE requirements.

Internal wetted portions meet NACE Standard MRO175 revision, when the

exterior of the regulator is not directly exposed to a sour gas environment, buried, insulated, or otherwise denied direct atmospheric exposure. Either of the available trim designs are in compliance.

Diaphragm flange bolting is standard bolting, and meets NACE MRO175 Section 6.3 requirements.

## APPLICATION AND SELECTION

### FUNCTIONAL OPERATION OF DIFFERENTIAL PRESSURE REDUCING REGULATORS

Differential pressure reducing regulators operate in accordance with the parameters as indicated in Fig. 1. Sometimes called “tracking” regulators, a differential reducer always has the P<sub>2</sub>-Outlet Pressure greater than the P<sub>LOAD</sub> - loading Pressure by a relatively constant pressure differential – determined by the range spring setting. (See Graph 1.)

If P<sub>LOAD</sub> decreases by 15 psig (1 barg), then P<sub>2</sub> will also decrease by the same 15 psig (1 Barg). If P<sub>LOAD</sub> increases by 29 psig (2 Barg), then P<sub>2</sub> increases by 29 psig (2 Barg). Thus, P<sub>2</sub> “tracks” P<sub>LOAD</sub>, with the differential pressure between P<sub>LOAD</sub> and P<sub>2</sub> being relatively constantly at ΔP diff, as determined by the range spring set pressure.

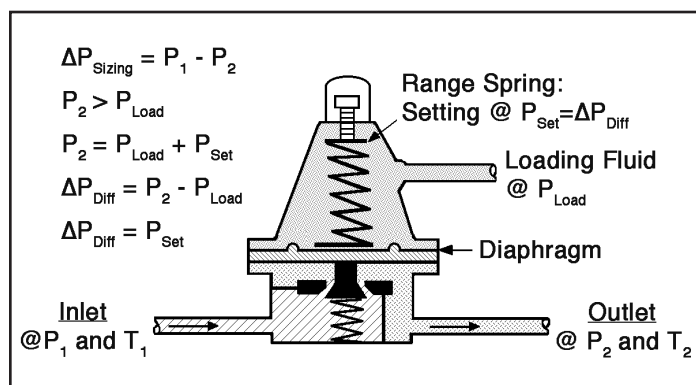
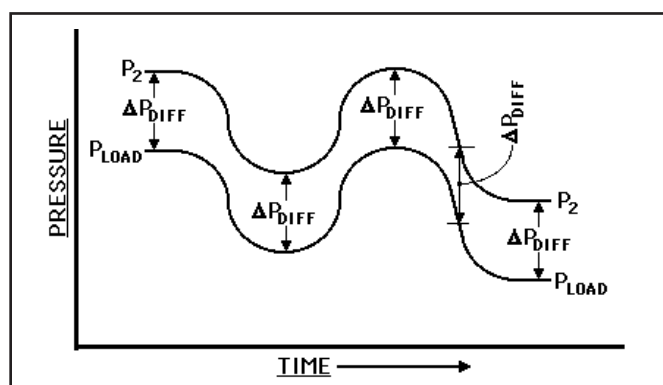

Figure1: HP-1+6+S



Graph 1

Cashco recommends that all Model HP-1+6+S units be sized and selected by Factory personnel. The following data must be available for a proper sizing and selection –

- Body Service Fluid – What is it? Liquid or gas? Specific gravity or weight density? Is it corrosive?
- Loading Service Fluid – What is it? Liquid or gas? Specific gravity or weight density? Is it corrosive?
- Inlet Pressure – P<sub>1</sub> (upstream pressure? Max, Norm, Min conditions?)
- Loading Pressure – P<sub>LOAD MAX</sub>, P<sub>LOAD NORM</sub>, P<sub>LOAD MIN</sub> ?
- Differential Pressure – ΔP<sub>DIFF</sub> or P<sub>SET</sub>? Allowable deviation of ΔP<sub>DIFF</sub> from P<sub>LOAD MAX</sub> to P<sub>LOAD MIN</sub>; i.e., acceptable “droop”?
- Desired Capacity – Cv, GPM, SCFH at P<sub>LOAD MAX</sub> and P<sub>LOAD MIN</sub> thru body?
- Body Fluid Temperature – T<sub>1</sub>?
- Loading Fluid Temperature – T<sub>LOAD</sub> ?
- Minimum Ambient Temperature – T<sub>AMB</sub> ?
- Body Fluid Viscosity – CP, SSU, CS?

## TECHNICAL SPECIFICATIONS

**TABLE 1  
CAPACITY TABLE - Cv – FULL PORT**

Differential Pressure $\Delta P$ Diff		SIZES 1/2", 3/4", 1" (DN15, 20, 25)			SIZES 1-1/2" (DN40)		
		Cv @ % Droop					
psid	(Bard)	10%	20%	30%	10%	20%	30%
15	(1.0)	.24	.44	.61	.42	.84	1.27
25	(1.7)	.51	.92	1.33	.98	1.96	2.95
40	(2.8)	.53	.83	1.11	1.69	2.71	3.65
50	(3.4)	.55	1.05	1.50	1.75	3.30	4.00
75	(5.2)	.61	1.15	1.65	1.80	3.90	4.23
100	(6.9)	.55	1.10	1.59	1.70	3.24	3.92
150	(10.3)	.63	1.28	1.70	1.80	3.96	4.40

METRIC CONVERSION FACTOR:  $Cv / 1.16 = kv$

**TABLE 2  
PRESSURE - TEMPERATURE - MATERIAL RATINGS**

Material Specifications		End Connections	Inlet Pressure		Outlet Pressure		Temperature			
Body & Spring Chamber	ASTM No.		psig	(Barg)	psig	(Barg)	° F	(°C)		
Carbon Steel CS/CS	A216 Gr.WCB	600# ASME B16.5 Flanged	1480	(102.1)	1480	(102.1)	-20 to 100	(-29 to +38)		
			1360	(93.8)	1360	(93.8)	200	(93)		
			1310	(90.3)	1310	(90.3)	300	(149)		
			1265	(87.2)	1265	(87.2)	400	(204)		
		900# ASME B16.5 Flanged	1500	(103.4)	2220	(153.1)	1500	(103.4)	-20 to 100	(-29 to +38)
					2035	(140.3)			200	(93)
					1965	(135.5)			300	(149)
					1900	(131.0)			400	(204)
		1500# ASME B16.5 Flanged or NPT	3000	(206.9)	1500	(103.4)	-20 to 400	(-29 to 204)		
		Stainless Steel SST/SST	A351 Gr. CF8M	NPT	3000	(206.9)	1500	(103.4)	-20 to 400	(-29 to 204)
				600# ASME B16.5 Flanged	1440	(99.3)	1440	(99.3)	-20 to 100	(-29 to 38)
					1240	(85.5)	1240	(85.5)	200	(93)
1120	(77.2)				1120	(77.2)	300	(149)		
1025	(70.7)				1025	(70.7)	400	(204)		
900# ASME B16.5 Flanged	1500			(103.4)	2160	(149.0)	1500	(103.4)	-20 to 100	(-29 to 38)
					1860	(128.3)			200	(93)
					1680	(115.9)			300	(149)
					1540	(106.2)			400	(204)
1500# ASME B16.5 Flanged	1500			(103.4)	3000	(206.9)	1500	(103.4)	-20 to 200	(-29 to 93)
					2795	(192.8)			300	(149)
					2570	(177.2)			400	(204)

## WEIGHTS & DIMENSIONS

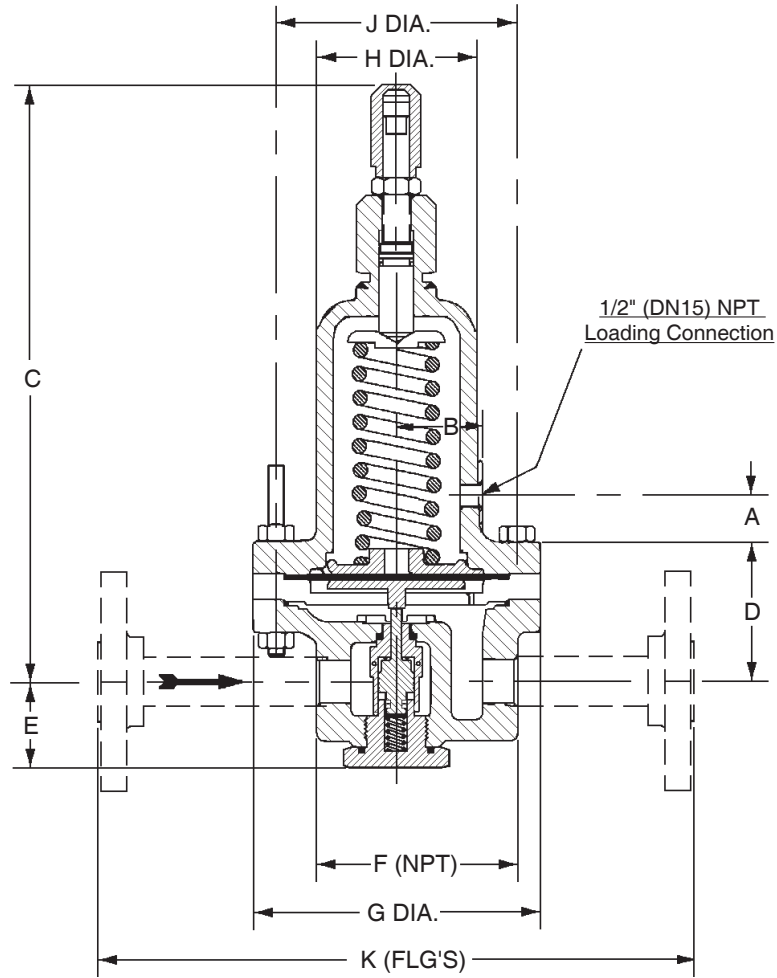

### DIMENSIONS

ENGLISH (in)											SHIPPING WEIGHT LBS
SIZE IN	A	B	C	D	E	F	G	H	J	K	
1/2, 3/4, 1	1.00	1.88	12.85	3.07	1.68	4.38	6.25	3.62	5.38	13.00	30
1-1/2	1.66	2.44	14.47	3.56	2.19	6.69	7.62	4.00	6.75	15.00	60
METRIC UNITS (mm)											SHIPPING WEIGHT KGS
SIZE (DN)	A	B	C	D	E	F	G	H	J	K	
(15, 20, 25)	25	48	326	78	43	111	159	92	137	330	13.6
(40)	42	62	368	90	56	170	194	102	171	381	27.2

## POSITION OF MOUNTING BRACKET STUDS

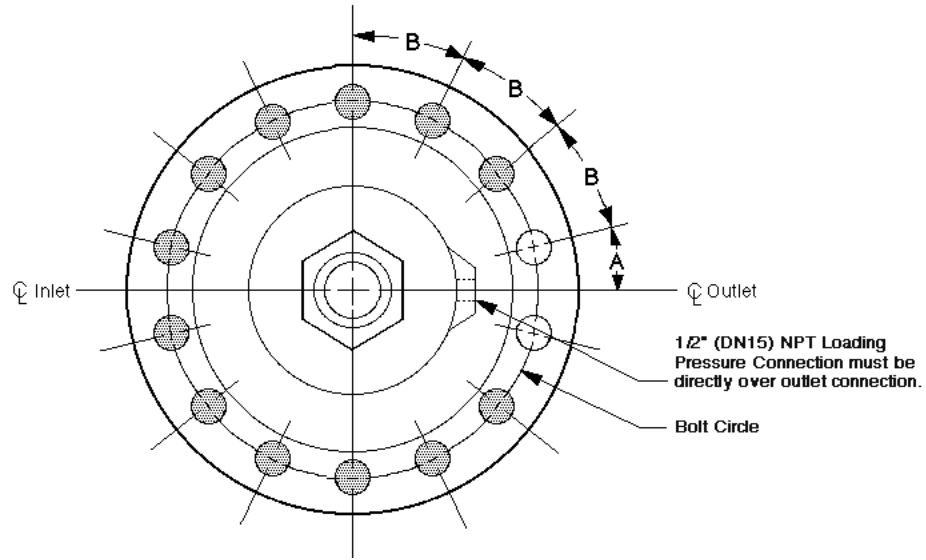

Position of longer studs used for mounting customer supplied bracket.



**Figure 2**  
1/2", 3/4" & 1" Body Size  
(DN15, 20, 25)

Position of two "Short" Cap Screws must straddle 1/2" (DN15) NPT Loading Pressure Connection.

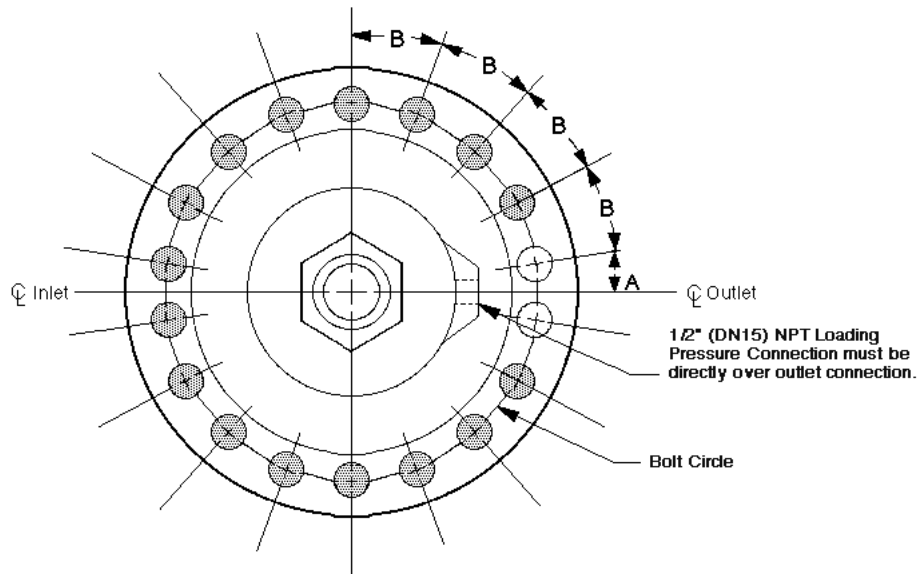

**Figure 3**  
1-1/2" (DN40) Body Size

BODY SIZE		NUMBER OF BOLT HOLES	BOLT CIRCLE	POSITION	
in	(DN)			A	B
1/2, 3/4, 1	(15, 20, 25)	14	5-3/8	12° - 51'-25"	25° - 42'-51"
1-1/2	(40)	18	6-3/4	10°	20°

---

---

## NOTES

# MODEL HP-1+6+S PRODUCT CODE 04/27/09

## "HIGH" PRESSURE DIFFERENTIAL

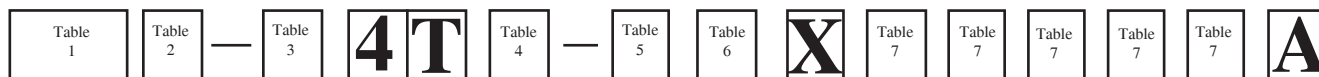

TABLE 1 - MODELS	
Description	CODE
Model HP-1+6+S (Opt-40) "NACE" Construction Differential Pressure Reducing Regulator	3N
Model HP-1+6+S "NON-NACE" Construction Differential Pressure Reducing Regulator	3S

TABLE 2 - SIZES		
Size		CODE
in	(DN)	
1/2"	(15)	4
3/4"	(20)	5
1"	(25)	6
1-1/2"	(40)	8

TABLE 3 - BODY/SPRING CHAMBER MATERIALS	
Body / Sp. Ch.	CODE
CS/CS	5
SST/SST	A

TABLE 4 - Product Classification Under European "Pressure Equipment Directive"		
PRODUCT	HAZARD CATEGORY	CODE
Standard	N/A	7
EUROPEAN <sup>1</sup> Consult Factory for Special Code	Sound Engineering Practice (SEP)	S
	CE Marked Hazard Cat I or II	E

<sup>1</sup> For products to be placed in service in Europe .  
(Ref PED-Art. 3, sec. 1.3; Art. 9; and Annex II Tables.)

TABLE 5 - END CONNECTIONS	
Description	CODE
NPT - Screwed	1
-30 Opt.- 600 LB RF Flgs. *	8
-30 Opt.- 900 LB RF Flgs. *	9
-30 Opt.- 1500 LB RF Flgs. *	A

\*Nipples & flanges of same material as body.  
CS or SST bodies only.

TABLE 6 - RANGE SPRINGS			
Size	psig	(Barg)	CODE
All	15-40	(.69-10.3)	1
1/2"-1"	30-150	(2.1-10.3)	2
1-1/2"	30-100	(2.1-6.9)	3
	80-150	(5.5-10.3)	4

TABLE 7 - OPTIONS		
Service Application	Body Material	CODE DRAWING #
NACE Service (Opt -40)	SST	32907
NACE Service (Opt -40)	CS	32909
Non-NACE Service	CS	32911