



**MODEL SCV-S**  
**Straight-Globe Pattern**  
**with Model 30 Reverse Action Actuator**

## APPLICATIONS

Used in pharmaceutical and biotechnical industries in production of shear sensitive microorganisms and many health care products for both human and animal consumption. Suitable for processed food and cosmetics production.

Would be found supporting fermenters, batching tanks, cookers, dryers and other similar sanitary equipment. Suitable in WFI (Water for Injection) systems.

Model SCV-S was designed primarily for clean steam service, and is applicable in saturated steam up to 150 psig (10.3 Barg), or superheated steam up to 150 psig (10.3 Barg) and 366°F (186°C) continuous service.

Also available for liquid or gas applications for temperatures up to 250°F (186°C) as a "food grade" product.

# MODEL SCV-S

## SANITARY GLOBE-STYLE CONTROL VALVES

The Model SCV-S is a **throttling**, pneumatically actuated control valve. This design provides a geometrically characterized plug for superior **throttling** dynamics, plus the unit's ease of cleanability and maintenance meet the requirements of sanitary control valves.

## FEATURES

- |                                 |   |
|---------------------------------|---|
| <b>Design Concept:</b>          | A control valve for <b>throttling</b> applications.   |
| <b>Two Body Configurations:</b> | Traditional straight-thru globe pattern, or angle body pattern, both self-draining. Forged 316L SST body material; barstock 316L SST bonnet material. |
| <b>Multiple Ports:</b>          | Both full and reduced port designs to optimize dynamic response.  |
| <b>Characteristic:</b>          | Linear.   |
| <b>Dual Stem Seal:</b>          | Two spring-energized stem seals ensure sealing against ingress of contaminants and egress of contained fluid. Available in two materials.             |
| <b>Polished Interior:</b>       | Interior of wetted surfaces mechanically polished and electro-polished to 10 micro-inch $R_a$ finish.   |
| <b>Exterior Finish:</b>         | SST portions of body electro-polished. All other metallic exposed surfaces are of SST or coated with epoxy.   |
| <b>Readily Accessible:</b>      | Unit can be easily and quickly disassembled in-line for inspection. Quick disconnect body-to-bonnet joint.  |
| <b>Cleaning Capability:</b>     | Unit designed for clean-in-place (CIP) and steam-in-place (SIP) systems.  |

## STANDARD/GENERAL SPECIFICATIONS

**Body Sizes:** Full Port – 3/4" (DN20), 1" (DN25), 1-1/2" (DN40).  
 Opt-12 Reduced Port – 1" (DN25) and 1-1/2" (DN40).

**Body Form:** Straight-Globe and Angle-Globe.

**End Connections:** Standard: Sanitary "Tri-Clamp®".  
 Designed to seal against weld type clamp liners per ISO 2852.  
 Optional: Butt weld (Opt-24).

**Inherent Characteristic:** Linear.

**Operating Pressure Range:** Function of actuator bench set range:  
 Full vacuum to +150 psig (Full vacuum to +10.3 Barg)

**Operating Temperature Range:** Up to +366°F (186°C); function of Trim Designation No. applied. Minimum – 0°F (-17°C).

**Maximum Operating Pressure Drop:** Function of actuator bench set range:  
 Up to 150 psid (10.3 Bard).

**Flow Capacity:** Per ISA 75.11 standard. See Tables 3 and 4.

Body Size		Port Size	Straight		Angle	
in	(DN)		Cv	kv	Cv	kv
3/4"	(20)	Full	2.8	2.4	2.9	2.5
1"	(25)	Full	6.0	5.1	6.6	5.6
		Opt-12 Red.	3.5	3.0	3.6	3.1
1-1/2"	(40)	Full	11.8	10.1	12.0	10.3
		Opt-12 Red.	6.2	5.3	6.8	5.8

**Rangeability:** 30:1 (FTO only).

**Flow Direction:** FTO – Flow-to-Open. (Not recommended for FTC direction.)

**Seat Leakage:** Per ANSI/FCI 70-2.  
 Metal seated – Class IV.  
 Composition seated – Class VI.

**Actuator:** Spring-Diaphragm type; multi-spring. Non-field reversible action.  
Direct: ATC-FO; Reverse: ATO-FC.

Direct: Increase in air "LOAD" extends actuator stem.  
Reverse: Increase in air "LOAD" retracts actuator stem.  
ATC-FO: Air-to-Close, Fail Open; Direct-acting.  
ATO-FC: Air-to-Open, Fail Closed; Reverse-acting.

**Exterior Finish:** Body/Bonnet – Electro-polished.  
 Actuator/Topworks – Epoxy paint per Cashco Spec. # S-1606, or SST.

**Maximum CIP Conditions:** CIP – Clean-in-Place.  
 Recommended: Maximum cleaning fluid pressure – 50 psig (3.4 Barg).

® Registered Tradename, Alfa-Laval Group, Tri-Clover Division.

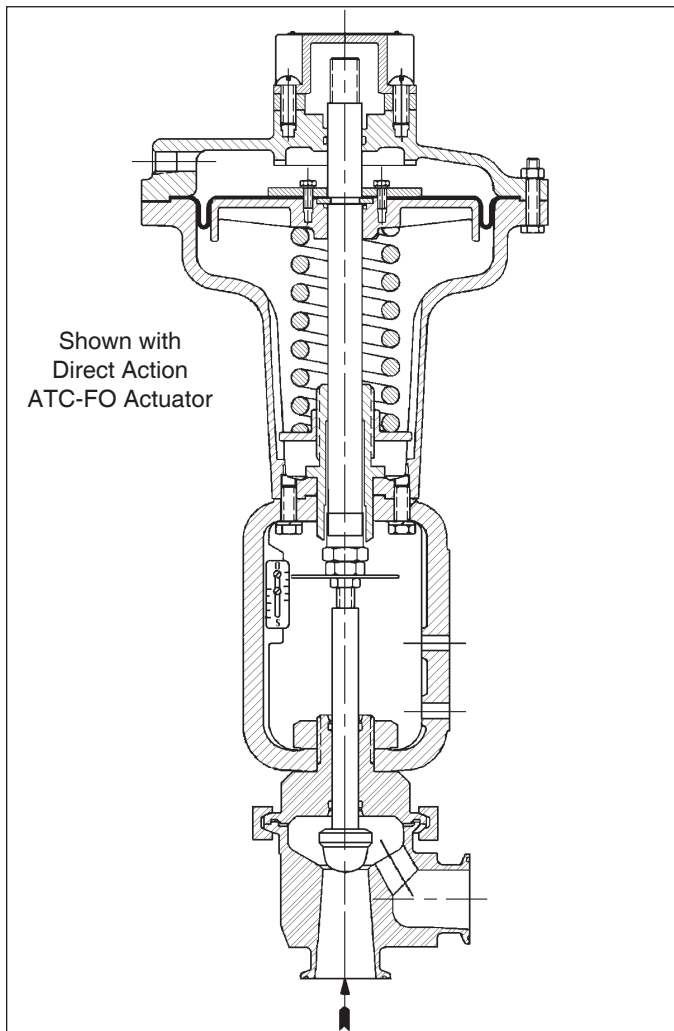

**FIGURE 1 – Angle body with Metal Plug**

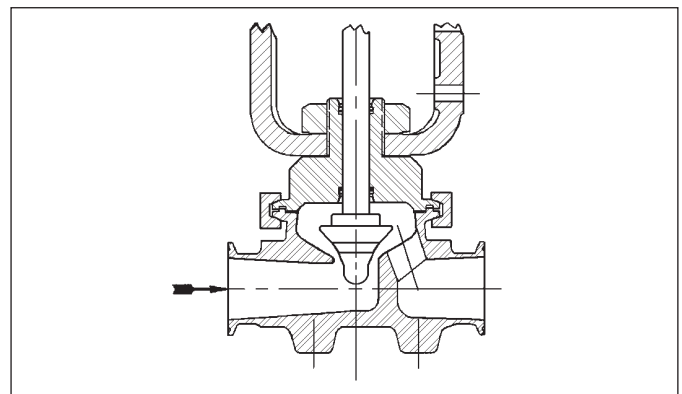

**FIGURE 2 – Straight Body with Composition Plug**

## BODY TECHNICAL SPECIFICATIONS

### Port Size, Stroke:

Body Size		Port Size				Nominal Stroke	
		Full		Opt-12 Reduced			
in	(DN)	in	(mm)	in	(mm)	in	(mm)
3/4"	(20)	.500	(12.7)	---	---	.625	(15.9)
1"	(25)	.688	(17.5)	.500	(12.7)		
1-1/2"	(40)	1.000	(25.4)	.688	(17.5)		

**NOTE:** Trim is interchangeable based on port size as each has the same stroke; i.e. 1" (25.4mm)- reduced port trim will directly transfer to 3/4" (19.1 mm)- full port, either angle or straight pattern.

### Installation Orientation:

Internal surfaces sloped and oriented to give "self-draining" with valve plug "open" when installed per Figure 3.

### End Connection Details:

Standard: For mating to piping with quick couple, mechanical joints; Alfa-Laval "Tri-Clamp". See Figure 4.

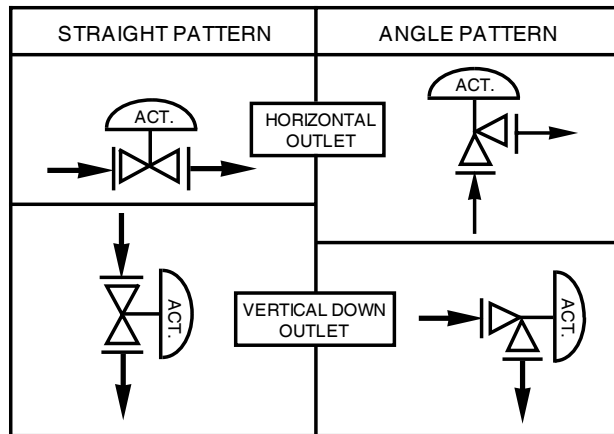

**FIGURE 3:**  
Installation Orientation

Nominal Body Size		Dimensions for Fig. 4					
		ID		OD		D1	
inch	(DN)	inch	(mm)	inch	(mm)	inch	(mm)
3/4"	(20)	0.625	(15.9)	0.98	(24.9)	0.80	(2.3)
1"	(25)	0.856	(21.7)	1.984	(50.4)	1.738	(44.1)
1-1/2"	(40)	1.356	(34.4)	1.984	(50.4)	1.738	(44.1)

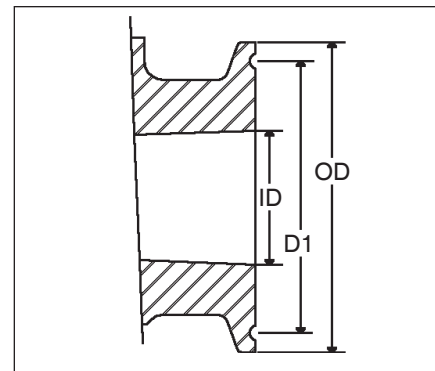

**FIGURE 4:** Std. "Tri-Clamp" End Connection

Nominal-Body Size		Dimensions for Fig. 5				
		ID	OD	t	C1	C2
Inch (DN)	inch (mm)	inch (mm)	inch (mm)	inch (mm)	inch (mm)	
3/4" (20)	0.620 (15.7)	0.750 (19.1)	.065 (1.65)	MIN. 1.69 (17.5)	0.75 (19.0)	
1" (25)	0.870 (22.1)	1.000 (25.4)				
1-1/2" (40)	1.370 (34.8)	1.500 (38.1)				

NOTE: Tube ends are for 16 Ga. tube.

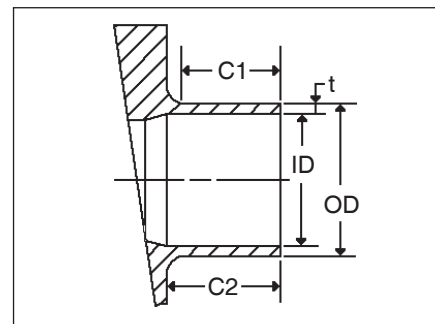

**FIGURE 5:** Opt-24 Butt Weld End Connection

## BODY SUB-ASSEMBLY MATERIAL SPECIFICATIONS

**Body:** Forged, ASTM F182, Gr. F316L (316L SST).

**Bonnet:** Barstock - 316L SST; ASTM A479, S31603, annealed.

**Plug/Stem Assembly:** Barstock - 316L SST; ASTM A479, S31603, annealed. See Table 5.

**Wetted Surface Finish:** Mechanically polished with 240 grit compound; manually polished where required. Electro-polished. Final surface is 10 micro-inch  $R_a$ . Final cleaning per Cashco Specification #S-1576.

**Gasket:** Expanded PTFE.

**Stem Seal:** Dual – Upper and lower. TDN S89LF utilizes o-ring seals with vented mid-zone. All other TDN's utilize spring-energized seals with non-vented mid-zone.

Materials – Selected with Trim Designation Number. Function of service fluid and maximum temperature. See Table 5.

**Bonnet Clamp:** Alfa-Laval Group, Tri-Clover Div., “Tri-Clamp”; 304 SST electro-polished. Two-piece clamp with SST bolt/nut fasteners.

NOTE: TDN = Trim Designation Number.

## ACTUATOR TECHNICAL SPECIFICATIONS

**Size, Stroke, & Volume:**

Basic Actuator Model No.	Diaph. Area		Nominal Stroke		Volumes			
					Clearance		Displacement	
	in <sup>2</sup>	(cm <sup>2</sup> )	in	(mm)	in <sup>3</sup>	(cm <sup>3</sup> )	in <sup>3</sup>	(cm <sup>3</sup> )
30D or 30R	30	(200)	0.625	(15.9)	15	(250)	20	(325)

**Ambient Temperature Range:** 0° to +175°F (-17° to +80°C).

**Bench Set Range:**

Actuator Model No.	Unit Action	Bench Set Range		Supply Air Pressure	
		psig	(Barg)	psig	(Barg)
30D-01	Direct: ATC-FO	4-15	(.28-1.0)	20	(1.4)
30R-01	Reverse: ATO-FC				
30D-02	Direct: ATC-FO	7-28	(.48-1.9)	35	(2.4)
30R-02	Reverse: ATO-FC				

## ACTUATOR SUB-ASSEMBLY MATERIAL SPECIFICATIONS (Model 30)

**Diaphragm Casings:** Cast aluminum, including cap.

**Spring Housing:** Integral with diaphragm casing; cast aluminum.

**Yoke:** Cast aluminum.

**Yoke Nut:** SST.

**Diaphragm:** Reinforced Neoprene.

**Diaphragm Plate:** Cast aluminum.

**Spring:** Plated steel.

**Spring Button:** Aluminum.

**Bolting – Diaphragm Casing, Yoke-to-Diaphragm Casing:** SST.

**Travel Indicator, Indicator Plate, & Screws:** SST.

**Spring Adjustor & Jam Nuts:** SST.

**Stem:** 316 SST.

## OPTION SPECIFICATIONS

- Option-3:** MANUAL HANDWHEEL. Overrides the actuator spring force to allow manual stroking of the valve. Single acting design, top-mounted, enclosed handwheel. For ATO-FC action, handwheel operator “opens” the valve against spring force; may be utilized as a travel stop to prevent full closure. For ATC-FO action, handwheel operator “closes” the valve against spring force; may be utilized as a travel stop to prevent full opening.
- Option-12:** REDUCED PORT. Standard full port body is replaced with an alternate body with its integral reduced port. See Pg. 3, “Port Size & Stroke” for actual port size. NOTE: To convert from one port size to the other port size for a given body size requires that the body be replaced as well as the plug/stem/diaphragm sub-assembly.
- Option-24:** BUTT WELD END CONNECTIONS – 16 Ga. Alternate to “Tri-Clamp” mechanical quick connect end connections. For connecting to 16 Ga. OD tubing. For butt weld jointing using automatic orbital welding process. Dimensions for the standard Opt-24 butt weld are indicated in Figure 5 on page 3; for butt welds of different dimensions consult factory.
- Option-68:** QUICK DISCONNECT STEM CONNECTOR. Standard threaded engagement stem connector is replaced with spring-loaded quick disconnect for fast uncoupling between actuator and body assemblies.

## TECHNICAL SPECIFICATIONS

**TABLE 1  
MAXIMUM PRESSURE VS. TEMPERATURE RATINGS**

Body Size		End Connection	Pressure		Temperature	
in	(DN)		psig	(Barg)	°F	(°C)
3/4"	(20)	Std. "Tri-Clamp®" or Opt.-24 Butt Weld	150	(10.3)	366	(186)
1"	(25)					
1-1/2"	(40)					

**TABLE 2  
MAXIMUM PRESSURE DROP – psid (Bard)  
ATO-FC; REVERSE ACTION  
ATC-FO; DIRECT ACTION  
FTO DIRECTION**

Body Size		Port-Orifice			Maximum Operating Pressure Drop		Seat	Actuator				Air Supply Pressure	
		Description	Size					Bench Settings		Model No.			
in	(DN)			inch	(mm)	psid	(Bard)		psig	(Barg)	Reverse Action	Direct Action	psig
3/4"	(20)	Full	0.500	(12.7)	150	(10.3)	Comp/Metal	4-15	(.28-1.0)	30R-01	30D-01	20	(1.4)
1"	(25)	Full	0.688	(17.5)	145	(10.0)	Comp	4-15	(.28-1.0)	30R-01	30D-01	20	(1.4)
					55	(3.8)	Metal	4-15	(.28-1.0)	30R-01	30D-01	20	(1.4)
					150	(10.3)	Comp/Metal	7-28	(.48-1.9)	30R-02	30D-02	35	(2.4)
		1-Step Reduced	0.500	(12.7)	150	(10.3)	Comp/Metal	4-15	(.28-1.0)	30R-01	30D-01	20	(1.4)
1-1/2"	(40)	Full	1.000	(25.4)	35	(2.4)	Comp	4-15	(.28-1.0)	30R-01	30D-01	20	(1.4)
					140	(5.9)	Comp	7-28	(.48-1.9)	30R-02	30D-02	35	(2.4)
					85	(5.9)	Metal	7-28	(.48-1.9)	30R-02	30D-02	35	(2.4)
		1-Step Reduced	0.688	(17.5)	145	10.0	Comp	4-15	(.28-1.0)	30R-02	30D-02	35	(2.4)
					55	(3.8)	Metal	4-15	(.28-1.0)	30R-01	30D-01	20	(1.4)
					150	(10.3)	Comp/Metal	7-28	(.48-1.9)	30R-02	30D-02	35	(2.4)

NOTE: Steam service with S36L Trim is 30 psid (2.1 Bard).

**TABLE 3**  
**Cv CAPACITY**  
**STRAIGHT-GLOBE**  
 $F_L = 0.9$

Body Size		Port Description	Cv @ % Travel										
in	(DN)		Min.	10%	20%	30%	40%	50%	60%	70%	80%	90%	100%
3/4"	(20)	Full	0.1	0.7	1.2	1.6	2.0	2.2	2.4	2.5	2.6	2.7	<b>2.8</b>
1"	(25)	Full	0.2	1.0	1.6	2.1	2.8	3.4	3.7	4.3	5.1	5.7	<b>6.0</b>
		Opt-12 Reduced	0.1	0.7	1.2	1.6	2.0	2.3	2.7	3.0	3.3	3.4	<b>3.5</b>
1-1/2"	(40)	Full	0.4	2.0	3.1	4.3	5.3	6.7	8.2	9.0	10.3	11.1	<b>11.8</b>
		Opt-12 Reduced	0.2	1.0	1.7	2.3	2.8	3.3	3.9	4.5	5.5	5.6	<b>6.2</b>

**TABLE 4**  
**Cv CAPACITY**  
**ANGLE-GLOBE**  
 $F_L = 0.9$

Body Size		Port Description	Cv @ % Travel										
in	(DN)		Min.	10%	20%	30%	40%	50%	60%	70%	80%	90%	100%
3/4"	(20)	Full	0.1	0.7	1.2	1.6	2.0	2.3	2.5	2.6	2.7	2.8	<b>2.9</b>
1"	(25)	Full	0.2	1.0	1.6	2.1	2.8	3.4	3.7	4.4	5.2	5.9	<b>6.6</b>
		Opt-12 Reduced	0.1	0.7	1.2	1.6	2.0	2.3	2.7	3.0	3.3	3.4	<b>3.6</b>
1-1/2"	(40)	Full	0.4	2.0	3.1	4.3	5.3	6.7	8.2	9.3	10.3	11.3	<b>12.0</b>
		Opt-12 Reduced	0.2	1.0	1.7	2.3	2.8	3.3	3.9	4.5	5.2	6.0	<b>6.8</b>

**TABLE 5**  
**TRIM MATERIALS vs. DESIGNATION NUMBERS**

Part Description	Metal Seat		GF-TFE Seat	V-TFE Seat
	S1L	S1LF	S36L	S89LF
Plug	316L SST	316L SST	316L SST	316L SST
Stem	--	--	316L SST	316L SST
Nut	--	--	SST	SST
Pin	--	--	TFE	TFE
Seat Disc	--	--	GF-TFE	V-TFE
Stem Seal	316 SST + Carbon Filled TFE	316 SST + V-TFE (Food Grade)	316 SST + Carbon Filled TFE	FKM (Food Grade)
Temperature Range	0° to +336°F -17° to -186°C	0° to +250°F -17° to +121°C	0° to +366°F -17° to +186°C	0° to +250°F -17° to +186°C
Service	Steam	Gas or Liquid	Steam	Gas or Liquid

GF-TFE = Glass Filled TFE  
V-TFE = Virgin TFE  
FKM = Fluorocarbon Elastomer

## MOUNTED ACCESSORY SPECIFICATIONS

**Positioners:**

General. Yoke mounted to unit. All feedback linkage exposed to elements of SST materials. Aluminum housing with corrosion resistant polyurethane paint. Standard with 2-gauge cluster. Pneumatic output load as required by actuator bench range. Adjustable zero, stroke, gain and damping settings. Field reversible actin. Dedicated airset recommended.

P/P Pneumatic. Model 9540L. Accepts 3-15 psig (0.2-1.0 Barg); 2-way split ranges 3-9 or 9-15 psig (0.2-0.6 or 0.6-1.0 Barg) input signals. Plastic cover with see-through panel to view internal gauges.

I/P Electro-Pneumatic. Model 9520L. Accepts 4-20 mA; 2-way split ranges 4-12 or 12-20 mA input signals. NEMA 3 enclosure, intrinsically safe. FM approved. Gauges mounted on external gauge block.

Mounting Bracket. P/P - Pneumatic uses a SST bracket.  
I/P – Electro Pneumatic uses a die cast aluminum bracket.

**Air Tubing:**

Standard instrument air tubing is imperial-Eastman “Impolene” thermo-plastic tubing with brass fittings.

Optional copper tubing with brass fittings, or SST tube and fittings.

**Airset:**

Model 5200P instrument air supply regulator. Use with positioners. Bracket mounted to actuator casing.

**Solenoid Valve:**

Standard Brass: Available in standard NEMA 3, 4 and 6 weatherproof model or NEMA 4 & 7 explosion-proof model. Brass body, 1/4" (DN8) female

NPT connections. Nipple mounted or bracket mounted to actuator casing. 120 VAC, 60 Hz power supply. Class F coil, continuous duty. 0.125" (3 mm) orifice, 50 psid (3.4 Bard) maximum pressure drop.

Gen. Purpose:

ASCO #8320G176.

X-Proof:

ASCO #EF8320G176.

Alternate SST: Same as standard unit, except with 303 SST body.

Gen. Purpose:

ASCO #8320G201.

X-Proof:

ASCO #EF8320G201.

Standard installation vents actuator and drives valve to failsafe position upon loss of electrical power.

**Position  
Indicating  
Switches:**

Standard: Yoke mounted, rotary trip switch; contains 1-SPDT switch. Switch rating is 15A @ 125 or 250 VAC. UL/CSA rating L96. Up to two switch units may be mounted per valve.

Gen. Purpose: Microswitch

#OP-AR. NEMA 4 enclosure.

X-Proof: Microswitch #EX-AR. For

“hazardous locations” NEMA 7, Class 1, Groups C & D; NEMA 9, Class II, Groups E, F and G.

Alternate: Proximity Controls Model #12ALO, 2-SPDT switches. Switch rating is 15A @ 125 or 250 VAC; proximity type. UL listed for Class I, Groups A, B, C, D; Class II, Groups E, F, G; Div. 1 and 2. CSA, BASEEFA and CENELEC listed. Enclosure per NEMA 1, 2, 3, 3R, 3S, 4, 4X, 6, 7, 9, 12 and 13.

**General Notes:**

Figures 6 and 7 are given in inches (mm).

Ship Weight  
(either body) –  
29 lbs. (13 kg)

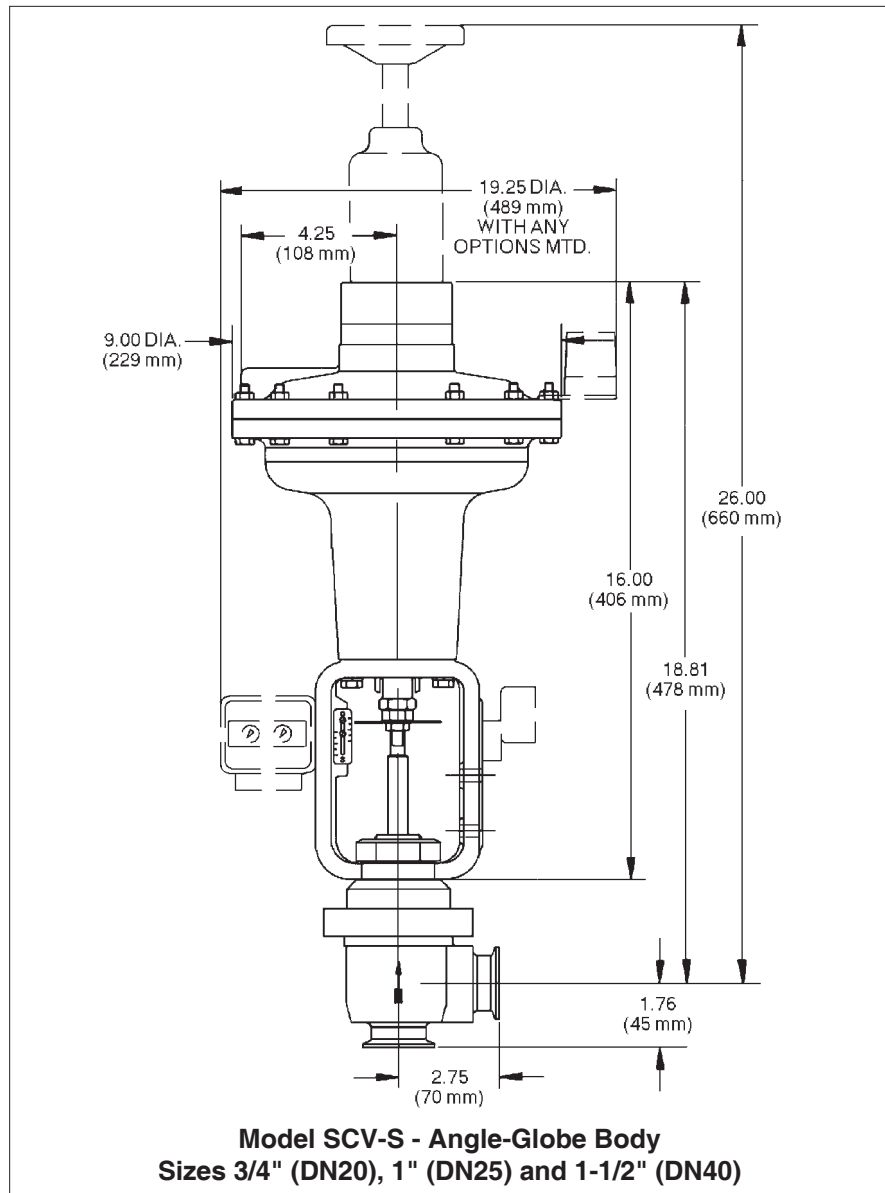

**FIGURE 6**

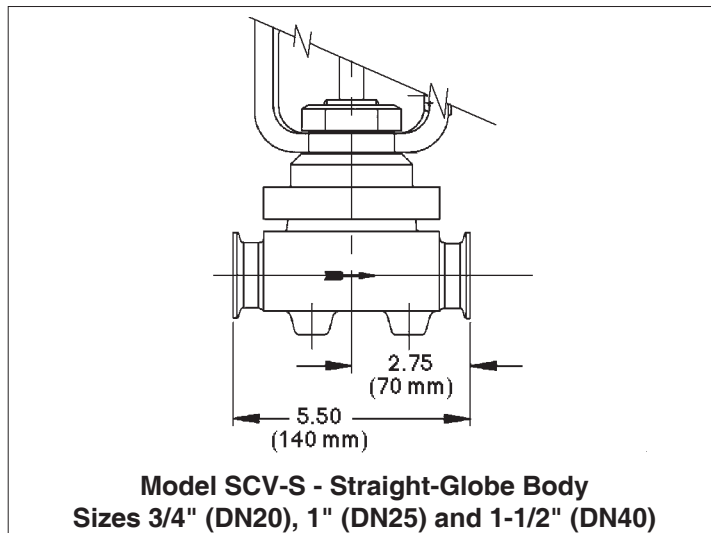

**FIGURE 7**

---

## NOTES

---

## NOTES

# MODEL SCV-S PRODUCT CODE 11/14/07



TABLE 1 - BODY / PORT SIZE			
Body Size		Port Size	
		Full Port	OPT-12 Reduced
in	(DN)	CODE	CODE
3/4"	(20)	5	--
1"	(25)	6	C
1-1/2"	(40)	8	D

TABLE 2 - BODY PATTERN	
Straight Globe	Angle Globe
CODE	CODE
A	G

TABLE 3 - TRIM DESIGNATION NO.	CODE
S1L	SL
S1LF	SF
S36L (GF-TFE Seat)	6L
S89LF (V-TFE Seat)	9F

TABLE 4 - PRODUCT CLASSIFICATION Under European "Pressure Equipment Directive"		
PRODUCT	HAZARD CATEGORY	CODE
Standard	N/A	7
EUROPEAN <sup>1</sup> Consult Factory for Special Code (PED does not apply to DN25 and below)	Sound Engineering Practice (SEP)	S
	CE Marked Hazard Cat I or II	E

<sup>1</sup> For products to be placed in service in Europe(See Cashco Spec. # 7E13)

TABLE 5 - END CONNECTION	CODE
Sanitary, Tri-Clamp	S
Opt-24, Butt Weld	B

TABLE 6 - ACTUATOR ACTION/MODEL NO.								
Body Size	Bench Set			End Connector	REVERSE: ATO-FC		DIRECT: ATC-FO	
	in (DN)	DESC.	psig (Barg)		MODEL #	CODE	MODEL #	CODE
ALL	Low	4-15	(.28-1.0)	Standard	30R-01	A	30D-01	B
				Opt-68: Q.D.	30R-93	T	30D-93	V
1" (25) 1-1/2" (40)	High	7-28	(.48-1.9)	Standard	30R-02	C	30D-02	D
				Opt-68: Q.D.	30R-94	W	30D-94	Y

Q.D. = Quick Disconnect

TABLE 7 - POSITIONER with AIRSET			
I/P-Electro-Pneu. Model #9520L	CODE	P/P-Pneumatic Model #9540L	CODE
Direct 4-20 ma	A	Direct 3-15 psig	1
Reverse 20-4 ma	B	Reverse 15-3 psig	2
Direct Split Range 4-12 ma	C	Direct Split Range 3-9 psig	5
Direct Split Range 12-20 ma	D	Direct Split Range 9-15 psig	6
Reverse Split Range 12-4 ma	E	Reverse Split Range 15-9 psig	7
Reverse Split Range 20-12 ma	F	Reverse Split Range 9-3 psig	8
No Positioner			0
Special Construction			X

When ordering a valve per one of Cashco's special drawings, the code "X" and the 5-digit number following over-ride all other options. Otherwise, proceed with the following tables.

TABLE 8 - TUBING & FITTING	CODE
NONE (NO Positioner, airset, solenoid, etc.)	0
STD-Impolene Plastic	1
Tubing, Brass Fittings, Copper Tubing, Brass Fittings	2
SST Tubing and Fittings	3

TABLE 9 - POSITION LIMIT SWITCHES				
Mfg / Model	Type	No. of Switch Units *	Trip Positions	CODE
NONE				0
Microswitch #OP-AR *	Rotary Trip NEMA 4	1	Plug Closed	1
		1	Plug Full Open	2
		2	Plug Closed & Full Open	3
Microswitch #EX-AR *	Rotary Trip NEMA 7 X-Proof	1	Plug Closed	A
		1	Plug Full Open	B
		2	Plug Closed & Full Open	C
Proximity Controls #12ALO	Proximity Rotary Trip X-Proof	2	Plug Closed & Full Open	K

\* Each "switch unit" contains 1-SPDT switch.

TABLE 10- AIRSET				
For Bench Settings		Airset Range		CODE
psig	Barg	psig	Barg	
4 - 15	(.28 - 1.0)	0-30	(0 - 2.1)	A
7 - 28	(.48 - 1.9)	0-60	(0 - 4.1)	B
No Airset				

TABLE 11 - ACCESSORIES	CODE
NONE (other than indicated on this Coder Sheet)	0
Manual Handwheel	A
VALVE MTD ACCESSORIES Any of the following: 3-Way Solenoid Valve 764P Press Controller Extra Airset(s) I/P Transducer Lockup Valve	9

Note: Use of a "9" code requires that a "99 Coder" sheet be completed.

Cashco, Inc.  
P.O. Box 6  
Ellsworth, KS 67439-0006  
PH (785) 472-4461 • FAX (785) 472-3539  
www.cashco.com  
email: sales@cashco.com • exportsales@cashco.com  
Printed in U.S.A. SCV-S-TB